



INSTALLATION & MAINTENANCE MANUAL

Condensing Units

CU 1-1.5

CUH 1-1.5

CUS 2-12

CUHS 2-12

CFCUS 5-10



ISO 14001
EM552086



ISO 9001
FM00542

About Airedale Products & Customer Services

WARRANTY, COMMISSIONING & MAINTENANCE

As standard, Airedale guarantees all non consumable **parts only** for a period of **24 months**, variations tailored to suit product and application are also available, please contact Airedale for full terms and details.

To further protect your investment in Airedale products, we have introduced Airedale Service, who can provide full commissioning services, comprehensive maintenance packages and service cover 24 hours a day, 365 days a year (UK mainland). For a free quotation contact our Airedale Service or your local Sales Engineer.

CAUTION  **Warranty cover is not a substitute for Maintenance. Warranty cover is conditional to maintenance being carried out in accordance with the recommendations provided during the warranty period. Failure to have the maintenance procedures carried out will invalidate the warranty and any liabilities by Airedale International Air Conditioning Ltd.**

SPARES

A spares list for 1, 3 and 5 years will be supplied with every unit and is also available from our Spares department on request.

TRAINING

As well as our comprehensive range of products, Airedale offers a modular range of Refrigeration and Air Conditioning Training courses, for further information please contact our Training Co-ordinator.

AIAC Ltd endeavours to ensure that the information in this document is correct and fairly stated, but none of the statements are to be relied upon as a statement or representation of fact. AIAC Ltd does not accept liability for any error or omission, or for any reliance placed on the information contained in this document.

The development of Airedale products and services is continuous and the information in this document may not be up to date. It is important to check the current position with AIAC Ltd at the address stated. This document is not part of a contract or licence unless expressly agreed.

No part of this document may be reproduced or transmitted in any form or by any means, electronic or mechanical, including photocopying, recording, or information storage and retrieval systems, for any purpose other than the purchaser's personal use, without the express written permission of AIAC Ltd.

© 2003 Airedale International Air Conditioning Limited. All rights reserved. Printed in the UK.

CUSTOMER SERVICES

For further assistance, please e-mail: enquiries@airedale.com or telephone:

UK Sales Enquiries	+ 44 (0) 113 238 7789	uk.sales@airedale.com
International Enquiries	+ 44 (0) 113 239 1000	enquiries@airedale.com
Spares Hot Line	+ 44 (0) 113 238 7878	spares@airedale.com
Airedale Service	+ 44 (0) 113 239 1000	service@airedale.com
Technical Support	+ 44 (0) 113 239 1000	tech.support@airedale.com
Training Enquiries	+ 44 (0) 113 239 1000	marketing@airedale.com

For information, visit us at our Web Site: www.airedale.com

Contents

DESCRIPTION	4
Standard Features	4
Optional Extras	5
GENERAL STATEMENT	6
WARRANTY	7
LOOSE ITEMS LIST	8
SITE INSTALLATION	8
Lifting	8
Positioning	8
Wall Mounting	8
MECHANICAL INFORMATION	9
Technical Data	9
Dimensions / Positioning / Weights	10
REFRIGERATION INFORMATION	13
Refrigerant Pipework Schematics	13
Unit Charge	13
Pipe Sizing Guide	13
Pipework Installation	13
Pressure Testing	14
Evacuation	14
Alternative Refrigerants	14
ELECTRICAL INFORMATION	15
Electrical Data – CU./CUH. 1 - 4	15
Electrical Data – CUS/CUHS 5 – 12	15
Electrical Data - CFCUS 5 – 10	16
Interconnecting Wiring	16
COMMISSIONING	18
Pre-Start Checks	18
Control Circuit Checks	19
Refrigerant Charging	20
Adding Oil	20
Running Checks	21
TROUBLESHOOTING	22
MAINTENANCE	26

Description

GENERAL

The condensing units comprise a compact housing incorporating all the necessary components and associated controls required. The compressor and controls are fitted in the weatherproof end section.

CE DIRECTIVE

Airedale certify that the equipment detailed in this manual conforms with the following EC Directives:

Electromagnetic Compatibility Directive (EMC)	89/336/EEC
Low Voltage Directive (LVD)	73/23/EEC
Machinery Directive (MD)	89/392/EEC in the version 98/37/EC
Pressure Equipment Directive (PED)	97/23/EC

To comply with these directives appropriate national & harmonised standards have been applied. These are listed on the Declaration of Conformity, supplied with each product.

STANDARD FEATURES

FAN & MOTOR UNITS

CU./CUH. 1 - 4

Axial flow fan assembly with low noise sickle type blades.

The external rotor motor allows the use of a low power output single phase speed controllable motor to power the fan.

The motor has inbuilt thermal overload protection and the assembly is protected against accidental contact by an integral punched finger guard.

CUS/CUHS 5 - 12

Axial flow fan assembly with low noise paddle type blades and inlet ring.

The external rotor motor allows the use of a low power output single phase speed controllable motor to power the fan.

The motor has inbuilt thermal overload protection and the assembly is supplied complete with a finger guard for protection.

CFCUS 5 - 10

Comprises a forward curved centrifugal fan, belt driven by a totally enclosed 3 phase motor, mounted on a slide base allowing ease of belt tensioning.

COMPRESSORS

CU./CUH. 1 - 1.5

Fully hermetic reciprocating compressor fitted as standard with Internal thermal motor protection. Compressor(s) are mounted to the base via the use of vibration isolators.

CUS/CUHS 2 - 12 & CFCU 5 - 10

Hermetic scroll compressors fitted as standard with:

- Internal thermal motor protection.
- Internal pressure relief valve.
- Compressor(s) are mounted to the base via the use of vibration isolators.
- Oil type may vary depending upon the refrigerant type, refer to **Technical Data**.

SERVICE VALVES

CU./CUH. 1 - 7.5

Units are provided with suction and liquid line shut-off valves fitted with Schrader connectors to facilitate connection of a service gauge manifold (except the CUS 5 - 7.5, which have no Schrader connection on the suction valve).

CUS/CUHS 10 - 12

Units are provided with liquid line shut off valves and rotalock valves fitted in the suction line.

SAFETY PRESSURE SWITCHES

Manual reset high and low pressure cut-out switches are fitted in the compressor end compartment as standard.

Description

HEAT PUMP UNITS

Heat pump units are equipped with a reversing valve, crankcase heater and suitably sized accumulator. A factory set defrost sensor is also fitted to defrost the outdoor coil when the unit is operating in heat pump mode.

CUHS 1 - 4

Equipped with a bi-directional expansion valve.

CUHS 5 - 12

Fitted with an expansion valve, check valve and sight glass.

CONTROLS

The control panel is equipped with the necessary PCB's, MCB's, contactors and other items to provide fully automatic safe operation.

HEAD PRESSURE CONTROL

CU./CUH.1 - 12

Head pressure is maintained by a factory fitted, pressure actuated, head pressure controller which varies the speed of the fan(s) to provide optimum control under varying ambient conditions.

CFCUS 5 - 10

Head pressure is maintained by a factory fitted set of pressure actuated opposed blade dampers which modulate to provide optimum control under varying ambient conditions.

OPTIONAL EXTRAS

Epoxy Coated Coils

In atmospheres where high corrosion is anticipated epoxy coated aluminium finned coils can be supplied.

Wall Brackets

(CU./CUH. 1 – 4)

Of a single multi-fit design in matching material and colour. Ready to assemble on site.

Defrost Drain Tray

(CUH/CUHS 1 – 4)

A trace heated stainless steel defrost drain tray can be fitted to units.

Hot Gas Bypass

For low load applications a hot gas bypass valve and in-line solenoid valve can be factory fitted to CUS 5 - 12 and CFCUS 7.5 - 10 (supplied loose on units CFCUS 5 - 6 and CUS 1 - 4).

General Statement

IMPORTANT

The information contained in this manual is critical to the correct operation and maintenance of the unit and should be read by all persons responsible for the installation, commissioning and maintenance of this Airedale unit.

SAFETY

The equipment has been designed and manufactured to meet international safety standards but, like any mechanical/electrical equipment, care must be taken if you are to obtain the best results.

- 1 **Service and maintenance of Airedale equipment should only be carried out by skilled personnel.**
- 2 **When working with any air conditioning units ensure that the electrical isolator is switched off prior to servicing or repair work and that there is no power to any part of the equipment.**
- 3 Also ensure that there are no other power feeds to the unit such as fire alarm circuits, BMS circuits etc.
- 4 Electrical installation commissioning and maintenance work on this equipment should be undertaken by competent and trained personnel in accordance with local relevant standards and codes of practice.
- 5 Refrigerant used in this range of products is classified under the COSHH regulations as an irritant, with set Occupational Exposure Levels (OEL) for consideration if this plant is installed in confined or poorly ventilated areas.
- 6 A full hazard data sheet in accordance with COSHH regulations is available should this be required.

SPARES

For ease of identification when ordering spares or contacting Airedale about your unit, please quote the unit type, unit serial number and the date of manufacture. This information can be found on the unit serial plate. An area has been provided on the front cover of this manual for this information to be recorded.

A spares list for 1, 3 and 5 years will be supplied with every unit and is also available from our Spares department on request.

SERIAL PLATE EXAMPLE

AIREDALE INTERNATIONAL AIR CONDITIONING LTD , LEEDS LS19 6JY	
UNIT TYPE	CUS 4HI
UNIT SERIAL No.	81543668-001 (63091072)
DATE OF MANUFACTURE	01/02/03
ELECTRICAL SUPPLY	380 V 3 PH 50 Hz
COMPRESSOR 1	3.8 FLA 23.0 LRA
CONDENSER FAN	0.7 FLA 1 PH 0.15 kW
SUPPLY FUSE RATING	10.0 A
REFRIGERANT TYPE & CHARGE	R407C
FACTORY TEST PRESSURE	HIGH SIDE 440 PSIG LOW SIDE 200 PSIG

Loose Items List

LIQUID LINE FILTER DRIER Matched to the refrigeration duty of the compressor, shipped in the compressor compartment.

Site Installation

LIFTING

Whenever a condensing unit is lifted, it should be from the base and, where possible, with all packing and protection in position. If any type of slinging is used, due care should be taken to ensure that the slings do not crush the casework or coil.

Due note should also be made of the fact that the compressor is at one end of the unit, and therefore the centre of gravity will also be towards that end.

If the unit is dropped, it should immediately be checked for damage.

NOTE: Keep all pipes capped during installation to prevent pipework contamination.

POSITIONING

The condensing unit should be positioned on a stable and even base. This base should be levelled to ensure that the compressor operates correctly without uneven internal stresses being transmitted to the compressor support springs.

Pipework sizes and routes should be set in accordance with good refrigeration practice.

Pipework and electrical connections are readily accessible.

Where multiple units are installed, due care should be taken to avoid the discharge air from each unit adversely affecting other units in the vicinity.

WALL MOUNTING (CU./CUH. 1-4)

When condensing units are wall-mounted due care should be taken to choose a position such that there will be an uninterrupted airflow over the coil under all normal operating conditions.

It is recommended that a defrost drain tray be fitted where heat pump condensing units are to be wall mounted to prevent ice from falling.

DEFROST DRAIN TRAY (CUH/CUHS 1 – 4 OPTIONAL)

Attach the optional defrost drain tray to the wall mounting brackets by first attaching the 2 drain tray brackets to the wall mounting brackets using 2 M6 screws, nuts and washers. Then attach the rear of the defrost drain tray to the wall mounting brackets using 2 M6 screws and washers. Attach the front of the defrost drain tray to the drain tray bracket using 2 M6 screws and washers.

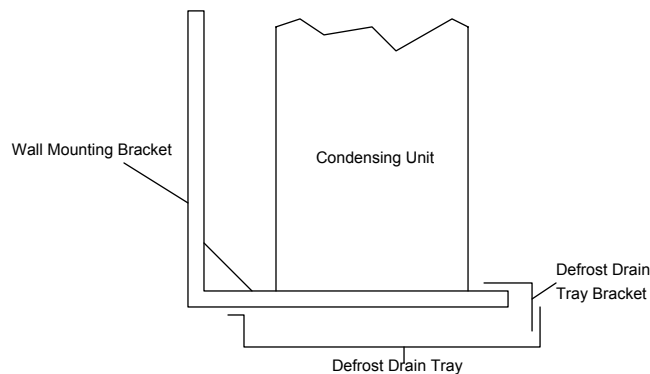

SERVICES

Refer to the **Technical Data, Dimensions / Positioning / Weights & Electrical Information.**

Mechanical Information

TECHNICAL DATA

CU./CUH.		1	1.5	2	2.5S	2.5T	3	3.5	4
Nominal Capacity - Cooling (1)	kW	3.30	4.50	5.10	7.60	7.60	8.70	10.80	13.10
Nom. Airflow	m ³ /s	0.80	0.80	0.80	0.80	0.80	0.80	1.45	1.80
Max. Fan Speed	rpm	840	840	840	840	840	840	840	840
Refrigerant		R407C							
Unit Refrigerant Charge	Kg	0.85	1.00	0.60	1.30	1.30	1.50	1.50	1.50
Oil Charge/Compressor	l	0.60	1.20	1.00	1.10	1.10	1.10	1.90	1.60
Liquid Line Conn.	in	F 1/4	F 1/4	F 1/4	F 3/8	F 3/8	F 3/8	F 3/8	F 1/2
Suction Line Conn.	in	F 1/2	F 1/2	F 5/8	F 3/4	F 3/4	F 3/4	F 3/4	F 3/4
Hot Gas Stub	in	1/2	1/2	1/2	1/2	1/2	1/2	1/2	1/2
Operating Weight (nom) CUS	kg	51.0	59.0	60.2	75.7	75.7	88.1	101.6	104.1
Operating Weight (nom) CUHS	kg	53.0	61.0	61.8	78.4	78.4	83.6	106.0	109.4

CUS/CUHS		5	6	7.5	10	12		
Nominal Capacity - Cooling (1)	kW	13.70	17.90	21.00	27.40	35.70		
Nominal Airflow	m ³ /s	2.00	2.00	2.25	4.45	4.45		
Max. Fan Speed	rpm	930	930	930	930	930		
Refrigerant Design Type		R407C						
Unit Refrigerant Charge	kg	2.40	2.40	3.63	4.76	4.76		
Oil Charge/Compressor	l	1.55	1.65	3.25	3.80	4.00		
Liquid Line Conn.	in	F 1/2	F 5/8	F 5/8	F 7/8	F 7/8	F =	Flare
Suction Line Conn.	in	F 7/8	S 1 1/8	S 1 1/8	S 1 1/8	S 1 3/8	S =	Sweat
Hot Gas Stub	in	5/8	5/8	7/8	7/8	7/8		
Weight:								
Operating (nom) CUS5 – 12	kg	141.0	144.0	208.5	261.0	266.0		
Operating (nom) CUHS5 – 12	kg	168.0	171.0	222.5	272.0	277.0		

CFCUS		5	6	7.5	10
Nominal Capacity - Cooling (1)	kW	14.80	19.70	24.80	32.30
Nominal Airflow	m ³ /s	1.89	2.08	2.89	3.20
Nom Speed @ 100Pa ESP	rpm	937	994	951	1014
Refrigerant Design Type		R407C			
Unit Refrigerant Charge	kg	2.40	2.40	4.80	4.80
Oil Charge/Compressor	L	1.55	1.65	3.25	3.8
Liquid Line	in	1/2	5/8	5/8	7/8
Suction Line	in	7/8	1 1/8	1 1/8	1 1/8
Operating Weight (nom)	kg	241	248	325	330

(1) Nominal Capacity based on 5°C mean evaporating temperature and a 35°C ambient.

Mechanical Information

DIMENSIONS / POSITIONING / WEIGHTS

CU. / CUH. 1 - 4

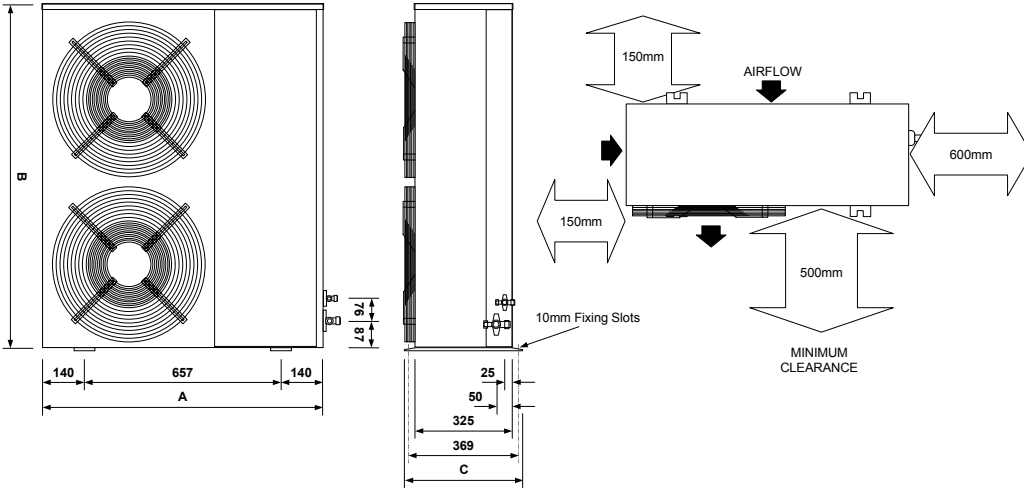

Models	Dimensions	A	B	C	Operating Weights
CU1	mm	937	843	395	51.0 kg
CU1.5	mm	937	843	395	59.0 kg
CUS2	mm	937	843	395	60.2 kg
CUS2.5S & T	mm	937	843	395	75.7 kg
CUS3	mm	937	1130	395	88.1 kg
CUS3.5	mm	937	1130	395	101.6 kg
CUS4	mm	937	1130	395	104.1 kg
CUH1	mm	937	843	395	53.0 kg
CUH1.5	mm	937	843	395	61.0 kg
CUHS2	mm	937	843	395	61.8 kg
CUHS2.5S & T	mm	937	843	395	78.4 kg
CUHS3	mm	937	1130	395	83.6 kg
CUHS3.5	mm	937	1130	395	106.0 kg
CUHS4	mm	937	1130	395	109.4 kg

- 1 Incoming Electrical Service holes (3 x 20mm Ø) to rear of unit.
- 2 Models CUS3 has 1 vertically aligned condenser fan.

OPTIONAL WALL MOUNTING BRACKET

Self-assembly, Multi-fit Construction

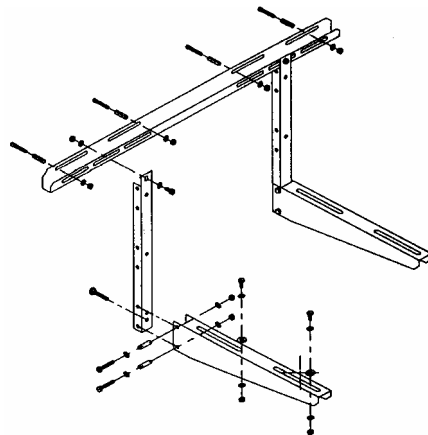

Mechanical Information

DIMENSIONS / POSITIONING / WEIGHTS

CUS/CUHS 5 - 7.5

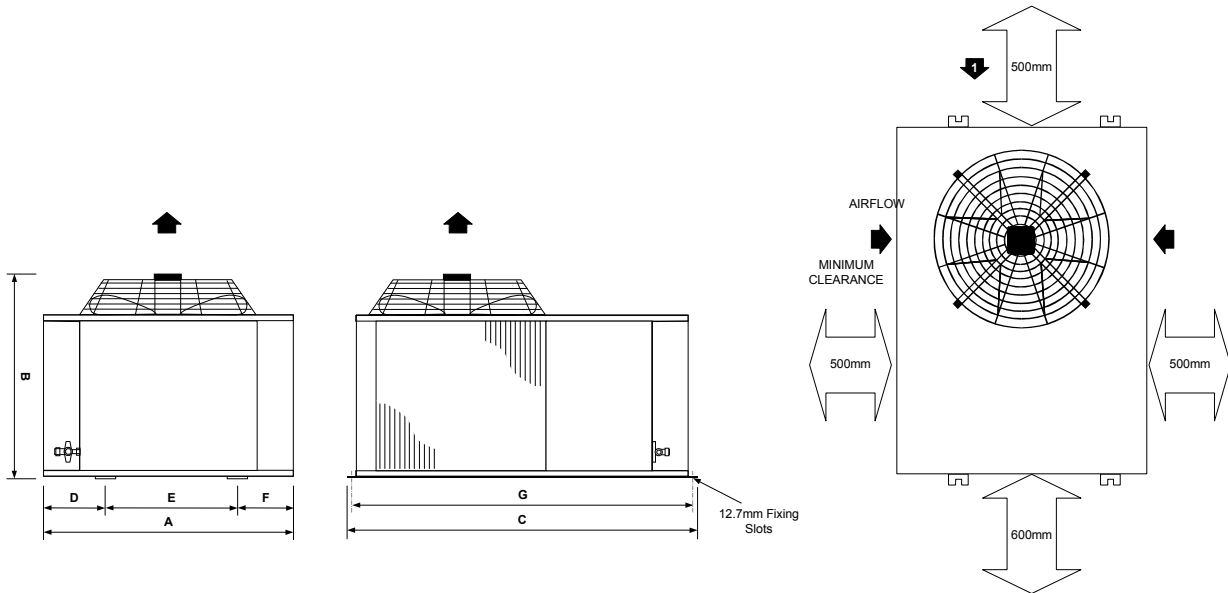

Models	Dimensions	A	B	C	D	E	F	G	Operating Weights
CUS5	mm	865	699	1213	213	457	195	1181	141.0 kg
CUS6	mm	865	699	1213	213	457	195	1181	144.0 kg
CUS7.5	mm	996	699	1441	193	610	193	1409	208.5 kg
CUHS5	mm	996	699	1441	193	610	193	1409	168.0 kg
CUHS6	mm	996	699	1441	193	610	193	1409	171.0 kg
CUHS7.5	mm	996	699	1441	193	610	193	1409	222.5 kg

- 1 Coil to this face on the CUS/CUHS 7.5 model only.
- 2 Incoming Electrical Service holes (3 x 20mm Ø) to rear of unit.

CUS/CUHS 10 - 12

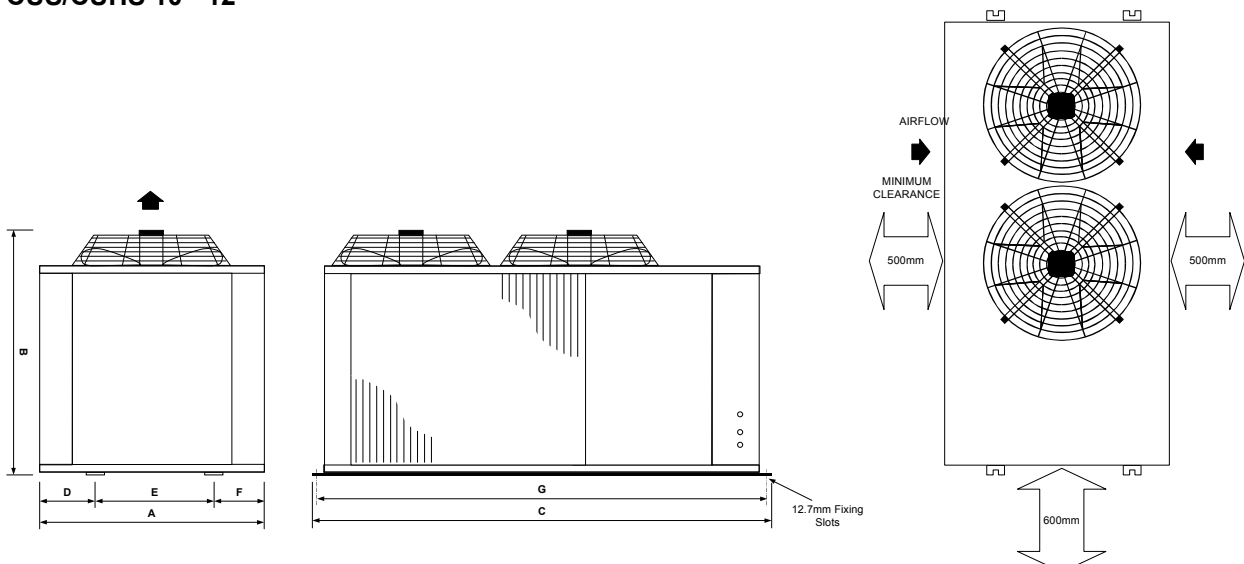

Models	Dimensions	A	B	C	D	E	F	G	Operating Weights
CUS10	mm	865	953	1770	204	457	203	1738	261.0 kg
CUS12	mm	865	953	1770	204	457	203	1738	266.0 kg
CUHS10	mm	865	953	1770	204	457	203	1738	272.0 kg
CUHS12	mm	865	953	1770	204	457	203	1738	277.0 kg

- 1 Incoming Services: Connections to left hand side of unit compressor compartment.

Mechanical Information

DIMENSIONS / POSITIONING / WEIGHTS

CFCUS 5 - 10

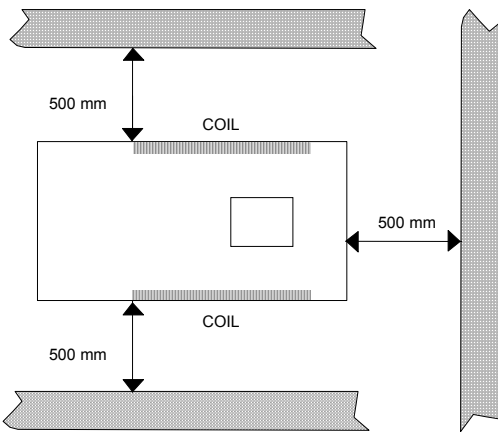
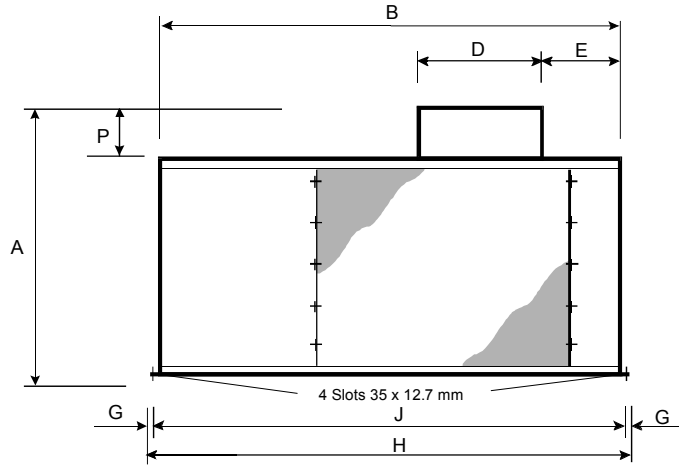
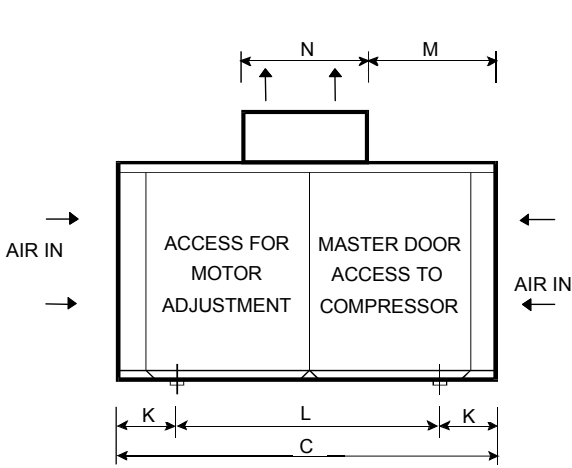

WEIGHTS

		Machine	Operating
CFCUS 5	kg	238.0	241.0
CFCUS 6	kg	245.0	248.0
CFCUS 7.5	kg	320.0	325.0
CFCUS 10	kg	325.0	330.0

CFCUS		5	6	7.5	10
A	mm	717	717	985	985
B	mm	1173	1173	1459	1459
C	mm	1016	1016	1148	1148
D	mm	575	575	560	560
E	mm	45	45	30	30
F	mm	557	557	824	824
G	mm	16	16	19	19
H	mm	1238	1238	1524	1524
J	mm	1206	1206	1486	1486
K	mm	203	203	224	224
L	mm	610	610	701	701
M	mm	161	161	194	194
N	mm	560	560	700	700
P	mm	160	160	160	160

- 1 Incoming Services: Connections to left hand side of unit compressor compartment.
- 2 Airflow and Maintenance Clearance: Please allow 500mm around the unit for airflow and maintenance purpose.
- 3 Dimensions D, E, M, N and P apply for units fitted with Head Pressure Control only, therefore dimensions will vary if Head Pressure Control is not fitted.

Refrigeration Information

REFRIGERANT PIPEWORK SCHEMATICS

CU. 1 - 12/CFCUS 5 - 10

OUTDOOR UNIT

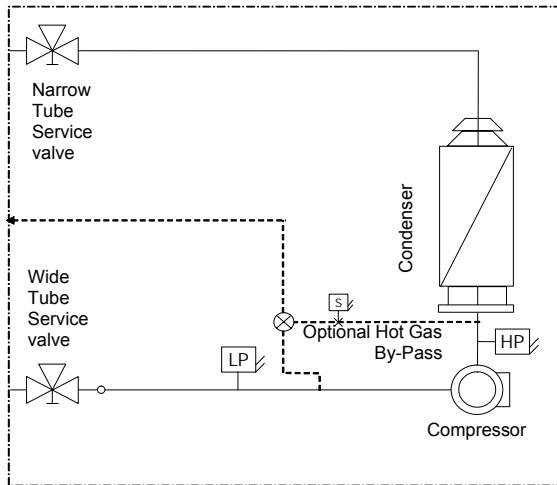

CUH. 1 - 12

OUTDOOR UNIT

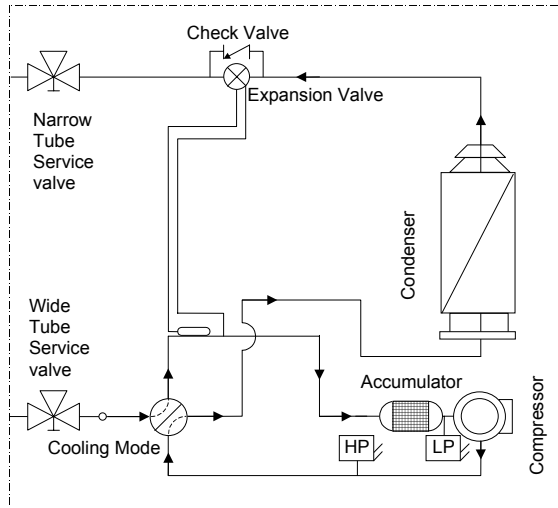

UNIT CHARGE

CU./CUH. 1 - 4

Units are shipped with a charge of R407C for a pipe run up to 7 metres (equivalent length).

CUS/CUHS 5 - 12

The units are shipped with a holding charge of inert gas to guard against contamination or moisture during shipping and storage.

The charge should be checked to indicate if leaks are present prior to evacuation.

If the charge appears to be either partially or totally lost, then the unit should be carefully checked for signs of physical damage.

PIPE SIZING GUIDE

It is important that the correct size refrigeration pipework is used to keep the system pressure drop to a minimum and promote correct oil return.

Pipework sizes and routes should be set in accordance with good refrigeration practice.

PIPEWORK INSTALLATION

CUS/CUHS 1 - 12

The suction line should be insulated.

Liquid lines should be insulated in areas of high temperature or when exposed to direct sunlight.

Refrigeration Information

PIPEWORK INSTALLATION

General

Special consideration should be given to vertical pipe runs and heat pump installation.

Unit performance will reduce if there are vertical rises of above 5m. Please consult Airedale Service for risers above 10m.

When insulating refrigerant lines, cut approximately 30 - 50cm longer than the distance between the units to ensure the insulation goes right upto the unit. Leave connections uncovered for leak testing.

Remove burrs to the ends of the copper tube, holding the tube downward to avoid allowing dirt to contaminate the tube.

Where applicable insert flare nuts removed from the pipework terminations and make a flare at the end of the copper tube to conform with the following:

- Inside surface is glossy and smooth
- Tapered sides are of uniform length
- Refrigeration lubrication is applied to matching surfaces

The installation of a sight glass close to the indoor unit is recommended.

Where applicable braze incoming pipe to rotalock service valve.

PRESSURE TESTING

When installation is complete, the system should be pressure tested.

Fill the system with dry nitrogen to a pressure of between 17 bar/250psig and 34bar/500 psig.

NOTE: The LP switch if fitted must be disconnected for pressures above 17bar/250 psig.

Record the pressure over a minimum of 60 minutes to detect major leaks (a 24 hour period should preferably be allowed).

If a reduction in pressure is detected, trace the leak and repair before conducting a further pressure test and charging.

EVACUATION

Evacuation for systems operating with R407C refrigerant to be carried out as follows (for alternative refrigerants please refer to Airedale).

Use a high vacuum pump and connect to the high and low pressure sides of the system via a gauge manifold fitted with compound gauges. A high vacuum gauge should be fitted to the system at the furthest point from the vacuum pump.

Triple evacuation should be used to ensure that all contaminants are removed.

Operate the vacuum pump until a pressure of 1.5 torr (200 Pa) absolute pressure is reached, then stop the vacuum pump to break the vacuum using oxygen free Nitrogen until the pressure rises above zero.

The above operation should be repeated a second time.

The system should then be evacuated a third time but this time to 0.5 torr absolute pressure.

Break with the correct refrigerant, until pressures equalise between the charging bottle and the system.

ALTERNATIVE REFRIGERANTS

If an alternative refrigerant is to be used, this must be with the approval of Airedale International Air Conditioning Ltd in order for the warranty to be valid.

Care must be taken to ensure that the refrigerant and compressor oil are compatible.

Electrical Information

GENERAL

A fused and isolated electrical supply of the appropriate phase, frequency and voltage should be installed.

As standard the equipment is designed for 230V, 1 Phase, 50Hz or 400V, 3 Phase, 4 wire 50Hz to all relevant IEE regulations, British standards and IEC requirements.

All mains and interconnecting wiring should be carried out to National and Local codes.

Wires should be capable of carrying the maximum load current under non-fault conditions at the stipulated voltage.

Avoid large voltage drops on cable runs, particularly low voltage wiring.

Once the refrigeration pipework is complete the electrical supply can be connected by routing the cable through the appropriate casing hole and connecting the cables as per the wiring diagram supplied with each unit.

Power to the indoor unit is normally taken from the outdoor unit. Should there be a separate supply for each unit, a control neutral must be fitted between the indoor and outdoor units.

ELECTRICAL DATA – CU./CUH. 1 - 4

			1	1.5	2	2.5S	2.5T	3.0	3.5	4.0
Unit Data										
Nominal Run Amps	(1)	A	6.0	9.7	10.3	14.3	6.4	7.1	8.8	9.5
Maximum Start Amps		A	35.0	59.0	49.6	78.6	39.1	46.6	56.7	67.0
Control Circuit		VAC	230	230	230	230	230	230	230	230
Mains Supply		V	230/1/50				400/3/50			
Rec. Mains Fuse		A	16	16	16	20	16	16	16	20
Max Incoming Mains		mm ²	6	6	6	6	6	6	6	6
Compressor										
Motor Rating		kW	1.1	1.7	1.7	2.5	2.5	2.9	3.7	4.0
Nominal Run Amps	(1)	A	5.5	9.4	9.6	13.6	5.7	6.4	7.8	8.2
Locked Rotor Amps		A	37.5	61.0	47.0	76.0	36.5	44.0	51.0	61.8
Crankcase Heater Rating	(2)	W	24	24	40	40	40	40	65	65
Type of Start	Direct on Line									
Condenser Fan										
Motor Rating		kW	0.15	0.15	0.15	0.15	0.15	0.15	0.15	0.15
Full Load Amps		A	0.65	0.65	0.65	0.65	0.65	0.65	0.65	0.65
Locked Rotor Amps		A	2.60	2.60	2.60	2.60	2.60	2.60	2.60	2.60

ELECTRICAL DATA – CUS/CUHS 5 – 12

			5	6	7.5	10	12
Unit Data							
Nominal Run Amps	(1)	A	11.4	13.5	15.2	21.1	26.6
Maximum Start Amps		A	68.3	100.8	103.8	131.6	146.6
Control Circuit (CUS)		VAC	230	230	230	230	230
Mains Supply		V	400/3/50				
Rec. Mains Fuse		A	20	25	32	40	40
Max Incoming Mains		mm ²	10	10	10	10	10
Compressor							
Motor Rating		kW	4.5	5.9	6.9	8.9	11.6
Nominal Run Amps	(1)	A	8.9	11.0	12.7	16.1	21.6
Locked Rotor Amps		A	62.5	95.0	98.0	120.0	135.0
Crankcase Heater Rating	(2)	W	65	65	50	50	50
Type of Start	Direct on Line						
Condenser Fan							
Motor Rating		kW	0.55	0.55	0.55	0.55	0.55
Full Load Amps		A	2.50	2.50	2.50	2.50	2.50
Locked Rotor Amps		A	5.80	5.80	5.80	5.80	5.80

(1) Nominal data based on 5°C evaporating temperature and a 35°C ambient.

(2) Heat pumps only.

Electrical Information

ELECTRICAL DATA - CFCUS 5 – 10

		5	6	7.5	10
Unit Data					
Nominal Run Amps	(1) A	14.0	16.1	19.3	24.5
Maximum Start Amps	A	91.7	124.2	119.9	168.3
Control Circuit	VAC	24	24	24	24
Mains Supply	V		400/3/50		
Rec. Mains Fuse	A	25	32	35	40
Max Incoming Mains	mm ²	10	10	10	10
Compressor					
Motor Rating	kW	4.50	5.90	8.14	9.70
Nominal Run Amps	(1) A	8.90	11.00	12.73	16.10
Locked Rotor Amps	A	62.50	95.00	98.00	120.00
Crankcase Heater Rating	W	65	65	50	50
Type of Start		Direct on Line			
Condenser Fan					
Motor Rating	kW	2.20	2.20	3.00	4.00
Full Load Amps	A	5.10	5.10	6.70	8.40
Locked Rotor Amps	A	29.15	29.15	41.40	48.30

(1) Nominal data based on 5°C evaporating temperature and a 30°C ambient.

INTERCONNECTING WIRING

Microprocessor Controlled (AD05)

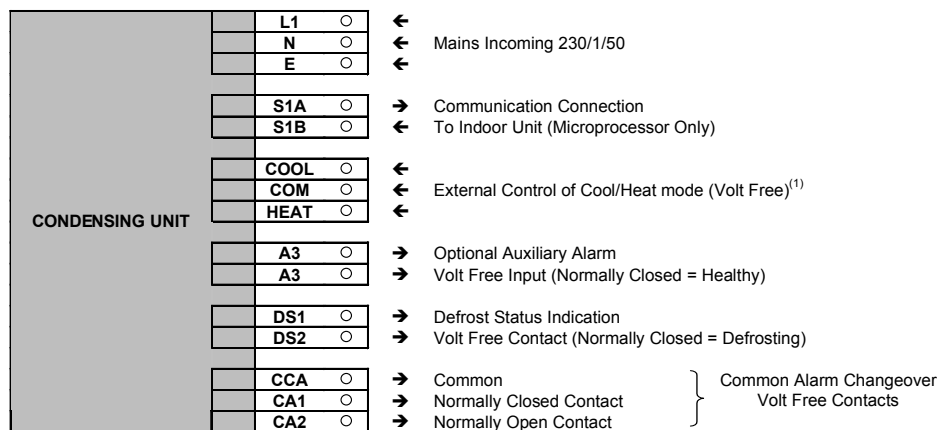

System Field Connections for AD05 Controlled Units

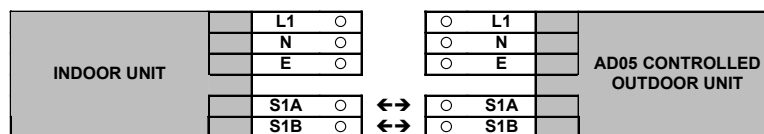

(1) The microprocessor (AD05) controlled condensing unit may be matched to non Airedale indoor air handling units.

A contact can be closed across either the Cool and Common or Heat and Common terminals. Ensure that the cooling and heating cannot be initialised simultaneously.

Electrical Information

INTERCONNECTING WIRING

Electro-Mechanically Controlled Units

CU.1-4

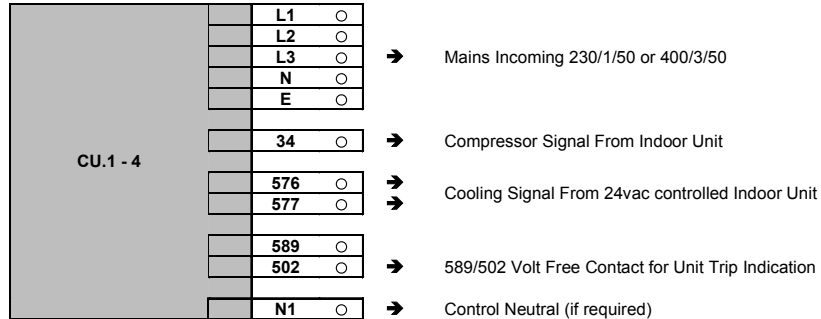

CUH.1-4

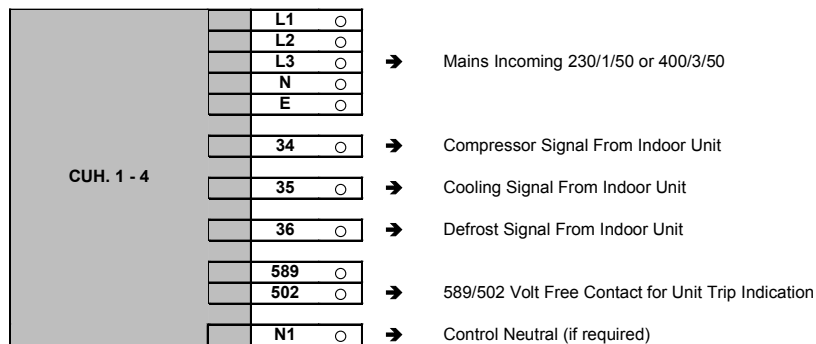

CUS5 – 12 & CFCUS 5 - 10

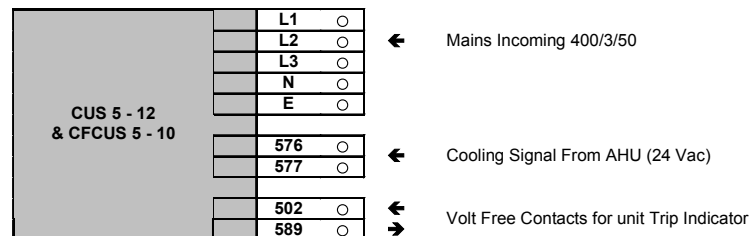

CUHS5 – 12

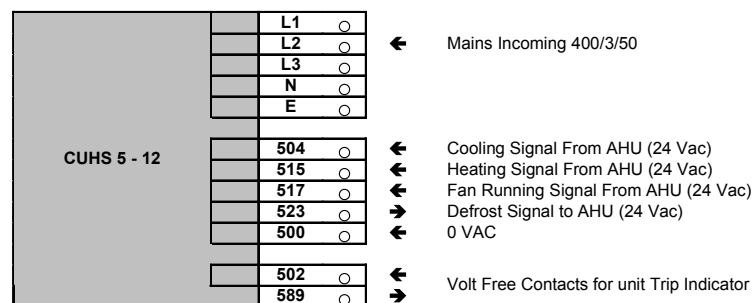

Commissioning

GENERAL

The following commissioning information is based on a complete matched Airedale system using R407C.

PRE-START CHECKS

Once the whole system has been installed it is most important that the following pre-start checks are made:-

GENERAL

- 1 The unit condition is satisfactory.
- 2 All pipework is complete and insulated where necessary.

ELECTRICAL

- 1 All electrical connections (both mains and control) are properly terminated.
- 2 The power supply is of the correct voltage and frequency.
- 3 External fuses/circuit breakers are of the correct rating.
- 4 The units are properly earthed in accordance with current regulations.
- 5 All pipework is earth bonded as required.
- 6 Check that there is a supply to the crankcase heater (if fitted) and ensure this is switched on for a minimum of 2 hours prior to the unit operation.

REFRIGERATION

- 1 The unit condition is satisfactory.
- 2 All pipework is complete and insulated where necessary.
- 3 All fans are able to rotate freely.
- 4 The system has been evacuated correctly.
- 5 Check the operation of the high and low pressure switch settings (if fitted). These should be as follows:-
 HIGH PRESSURE SWITCH - 27 Bar (400 psi) - CUT OUT
 LOW PRESSURE SWITCH - 0.5 Bar (7 psi) - CUT OUT
 2.5 Bar (37 psi) - CUT IN
- 6 The low pressure switch is automatically reset. The high pressure switch must be reset by either switching the unit off/on at the isolator, or de-energising the compressor signal from the indoor unit.

FAN SPEED / HEAD PRESSURE CONTROL CUS/CUHS 1 - 4

The head pressure control (if fitted), allows control to be achieved in ambients down to -20°C.

Head pressure can be controlled by setting the fan speed to the desired range and operating in the Cut off mode, whereby the voltage output to the fan is varied between 0-100%.

To adjust the fan speed, turn the slot headed screw on the transducer to the desired output.

DEFROST CONTROL (CU.1-4)

Defrost is controlled by a factory set defrost timer via a coil temperature sensor.

Commissioning

CONTROL CIRCUIT CHECKS

Please refer to the Airedale matched indoor unit manual for further details.

Cooling Only & Heat Pump

- 1 Disconnect the compressor power wiring from the compressor contactor. Switch on mains power.
- 2 Check status of the Alarm LED's on the microprocessor, refer to information provided with unit.

Under normally stand alone operation LED 4 will flash at 1 second intervals when the compressor anti-cycle delay is active.
- 3 After 4 minutes LED 4 will cease flashing and remain constant.
- 4 Select Cooling mode on the indoor unit and check for continuity between the COOL and COM terminals on the microprocessor.
- 5 The compressor should switch on.
- 6 De-select Cooling mode on the indoor unit and check for no continuity between the COOL and COM terminals on the microprocessor.
- 7 The compressor should switch off.
- 8 Switch off mains power and reconnect compressor power wiring.

Heat Pump Units

Follow steps 1-7 above and then check heating operation as described below:

- 1 Select heating mode on the indoor unit and check for continuity between the HEAT and COM terminals on the microprocessor.
- 2 Check status of the Alarm LED's on the microprocessor, refer to information provided with unit.

Under normally stand alone operation LED 4 will flash at 1 second intervals when the compressor anti-cycle delay is active.
- 3 After 4 minutes LED 4 will cease flashing and remain constant.
- 4 The compressor should switch on.
- 5 De-select heating mode on the indoor unit and check for no continuity between the HEAT and COM terminals on the microprocessor.
- 6 The compressor should switch off.
- 7 Switch off mains power and reconnect compressor power wiring.

Commissioning

REFRIGERANT CHARGING

The following information is based on a complete Airedale matched system and indicates the approximate amount of refrigerant charge required. It is also assumed that the system has been designed within operating parameters and to good refrigeration practice.

NOTE: It is important that the system is charged with the correct amount of refrigerant. Remember, a seriously over or undercharged system may lead to major component failure.

The final refrigerant charge level should be set by the design evaporating and condensing pressures, together with a full or nearly full sight glass.

The suction and discharge pressures should be constantly monitored whilst charging is in progress.

NOTE:- The sight glass level must be checked in the COOLING MODE ONLY.

ADDING REFRIGERANT

CU./CUH. 1 – 4

Supplied pre-charged for up to 7m pipe runs (equivalent length), please refer to the table below for additional charging guidance.

CUS/CUHS 5 – 12 & CFCUS 5 – 10

Supplied with a holding charge, the charge in the Technical Data tables is based on approximately 30m pipe runs (equivalent length).

The following approximate amounts should be added to the system for every additional metre of pipe run above the standard charge:

System	Additional Grams Per Metre Pipe Run
CU/CUH 1 – 1.5	24g
CUS/CUHS 2	28g
CUS/CUHS 2.5 – 3.5	67g
CUS/CUHS. 4	119g
CUS/CUHS & CFCUS 5	125g
CUS/CUHS & CFCUS 6 – 7.5	210g
CUS/CUHS & CFCU 10	384g
CUS/CUHS 12	384g

ADDING OIL

CU/CUH 1– 1.5

The initial oil charge in the compressor is suitable for pipe runs up to 20m (equivalent length).

CUS/CUHS 2 – 12 & CFCUS 5 – 10

The initial oil charge in the compressor is suitable for pipe runs up to 30m (equivalent length).

For longer pipe runs add 26 g of oil for every ADDITIONAL 0.45 kg of refrigerant added up to the maximum permissible equivalent pipe runs stated. Please consult Airedale for further details.

Commissioning

SYSTEM READINGS

NOTE :- The sight glass should only be used as an assistance to charging as the charge level showing in the glass will vary according to different operating conditions. This is especially noticeable with the heat pump units where the system may appear to be undercharged in the heating mode.

Evaporating temperature (suction gauge) should read approximately 2°C. to 3°C. with a room (return air temperature) of approximately 22 °C.

Condensing temperature (as read on the discharge gauge) should be in the region of 45 to 46 °C. with an external ambient temperature of 30°C (Condensing is normally 15 °C. above ambient).

RUNNING CHECKS

Once the system has been charged, the following running checks should be carried out:-

Check the operation of the fan speed controller by observing an increase in fan speed if the outdoor coil is temporarily partially blocked.

If the system is a heat pump option, check that the reversing valve switches over from cooling to heating and vice-versa.

NOTE: Head pressure control also operates in heating mode by slowing down the outdoor unit fan as the system pressure rises. This can be checked by partially blocking the inlet grilles of the indoor unit and observing the outdoor unit fan slowing down.

IMPORTANT

FINALLY AND MOST IMPORTANT - Fill in the commissioning sheet and return a copy to the factory to ensure that the warranty on the unit will be valid.

ALARM DIAGNOSTIC OPERATION (CU./CUH.1-4)

Unit control is via a microprocessor board found inside the control panel of the unit. The board features 4 Red LED alarm indicators to indicate specific outdoor controller alarms which should be checked when troubleshooting.

During situations when there is more than one alarm present the LED's will only indicate one alarm based on a priority sequence shown below.

Priority	Alarm Description	ALARM			
		LED 1	LED 2	LED 3	LED 4
1	A1 – Low Pressure Fault	On			
2	A2 – High Pressure Fault		On		
3	A3 – Auxiliary Alarm			On	
4	A4 or A5 Outdoor Fan Fault	On	On		
5	T2 – Coil Sensor Fault		Flashing		
1	Compressor Delay Active				Flashing
2	S1 Communications Fault				On

- LED4 will operate independently of the other alarm LEDs and will follow its own priority sequence, as indicated in the table.
- LED 4 will also flicker intermittently when the controller is communicating with the indoor board.
- The Airedale matched indoor units can be configured to a Master/Slave function, refer to indoor unit manuals for details.
- Master/Slave control refers to a number of indoor units in one area being controlled at one designated indoor unit by one command. This does not refer to connection to a proprietary commercial BMS system.

Troubleshooting (CU./CUH. 1– 4 Only)

FAULT	POSSIBLE CAUSE	REMEDY/ACTION
CRITICAL ALARMS:		
Aux. Alarm (LED 3 On)	Auxiliary Trip.	Check operation of customer-added alarm function.
Outdoor Fan Fault (LED 1 & 2 On)	Fan Trip.	Check and (if necessary) replace fan.
Coil Sensor Fault (LED 2 flashing 1 Hz)	Faulty Sensor.	Replace sensor.
No Cooling/Heating (LED 4 flashing 1 Hz)	Compressor Protection Delay.	Wait for a maximum of 10 minutes then re-check.
Head Pressure too high/HP cut-out operated (LED 2 On)	Condenser coil clogged or dirty.	Clean condenser.
	Overcharge of refrigerant. Normally troublesome in warm weather.	Remove excess refrigerant from system.
	Air or other non-condensable gas in system.	Evacuate system and re-charge with new refrigerant.
	Head pressure controller faulty.	Check fan speed controller - if faulty - replace.
Compressor short cycles or LP cut-out operated (LED 1 On)	Fan not operating or operating inefficiently.	Check motor - if faulty - replace.
	LP switch faulty (if fitted).	Check cut out pressure and replace if necessary.
	Dirty indoor unit filters.	Replace.
	Dirty or icing evaporator (reduced airflow).	Defrost and/or clean. Check gas charge and expansion valve.
	Lack of refrigerant (bubbles in sight glass only as indication).	Check for leaks - repair and recharge system.
	Clogged filter drier (pressure/temperature drop across it).	Replace.
	Condenser fan running at full speed in winter (full airflow).	Check fan speed controller setting - if faulty - replace.
Start up problems in very low ambients or when long pipe runs are experienced.	Check for low suction pressures on start-up and fit a low ambient start kit if required, or check operation of system if already fitted.	

Troubleshooting

FAULT	POSSIBLE CAUSE	REMEDY/ACTION
Unit Will Not Start	No power.	Check power supply to the controller.
	Wired incorrectly.	Check wire connections in accordance with wiring diagram on control box lid.
CU./CUH. 1- 4 Only	Loose wires.	Check all wires, connections, terminals etc.
	Microprocessor failure.	If fans can be operated by bypassing the microprocessor, then the microprocessor is faulty and requires replacing/investigation.
Compressor not operating	No power to compressor	Check isolator, fuses, MCBs, contactor and control circuit wiring
	Low pressure switch operated (if fitted) (large or complete loss of refrigerant charge).	Repair leak and recharge system - if completely out evacuate before charging.
	Condenser fan thermal trip open circuit.	Investigate and correct.
	Seized compressor, possibly due to lack of oil (piston/crank seizure) broken valve reed jamming piston etc).	Replace compressor - investigate oil trapping and general installation.
	Defective compressor motor.	Check winding resistances - replace compressor. If burnt out follow burn out procedure using suction line burn-out drier.
Noisy Compressor	Expansion valve malfunction (abnormally cold suction line).	Ensure feeler bulb is tight on suction and superheat is correct (normally 5 to 6°C). Replace power assembly or valve as necessary.
	Lack of oil.	Repair leaks if any, add oil if required but not too much. Investigate pipe system and trapping. If no oil still, drain compressor and measure in correct quantity.
	Broken or damaged compressor valve reed (compressor knocking).	Replace compressor (possible other symptom is that it will have high suction pressure).
	Worn or scored compressor bearing. (excessive knocking).	Replace compressor.
Head Pressure too high/HP cut-out operated	Condenser coil clogged or dirty.	Clean condenser.
	Overcharge of refrigerant. Normally troublesome in warm weather.	Remove excess refrigerant from system.
	Air or other non-condensable gas in system.	Evacuate system and re-charge with new refrigerant.
	Head pressure controller faulty.	Check fan speed controller - if faulty - replace.
	Fan not operating or operating inefficiently.	Check motor - if faulty - replace.
CFCUS Units - Head pressure damper seized.	Free off and lubricate.	
Head pressure too low	Fan operating too fast in low ambient conditions.	Check fan speed controller adjustment - if faulty - replace.

Troubleshooting

FAULT	POSSIBLE CAUSE	REMEDY / ACTION
Compressor short cycles or LP cut-out operated	LP switch faulty (if fitted).	Check cut out pressure and replace if necessary.
	Dirty indoor unit filters.	Replace.
	Dirty or icing evaporator (reduced airflow).	Defrost and/or clean. Check gas charge and expansion valve.
	Lack of refrigerant (bubbles in sight glass only as indication).	Check for leaks - repair and recharge system.
	Clogged filter drier (pressure/temperature drop across it).	Replace.
	Condenser fan running at full speed in winter (full airflow).	Check fan speed controller setting - if faulty - replace.
Suction Pressure too low	Start up problems in very low ambients or when long pipe runs are experienced.	Check for low suction pressures on start-up and fit a low ambient start kit if required, or check operation of system if already fitted.
	Low evaporator airflow.	Check fan motors, belts and drives.
	Flash gas (bubbles in sight glass) at expansion valve.	Investigate for refrigerant leaks, repair and re-charge system.
	Clogged filter drier (pressure / temperature drop across it).	Replace.
	Obstruction in liquid line solenoid valve.	Inspect, clean or replace.
	Obstruction in expansion valve.	Inspect, clean or replace.
Defrost cycle not initiating	Unit set for cooling only.	Check links.
Condenser fan not operating - power on	Power supply failure.	Check power supply at circuit breaker.
	Wiring to motor.	Check voltage at motor terminals.
	Motor / fan assembly jammed.	Isolate unit and check free rotation of motor/fan assembly. If faulty - replace.
	Motor internal overheat protector tripped.	Carry out continuity check at terminals "TK" in motor terminal box. If tripped and motor hot - check bearings. If tripped and motor cold - replace motor.
	Faulty motor windings/capacitor.	Motor humming would indicate fault in motor or capacitor. Check windings for continuity and if OK replace capacitor.
	Minimum speed set too low.	Adjust head pressure controller to suit.
	Faulty pressure sensor.	Check electrical connections are secure at controller and pressure sensor. Replace controller and sensor (as they are matched sets).
	Faulty Fan Speed Controller.	Link wires "line" and "load" to bypass controller. If motor runs full speed - replace unit.

Troubleshooting

FAULT	POSSIBLE CAUSE	REMEDY / ACTION
Condenser fan runs too fast	High ambient condition or excessive re-circulation of air around condenser coil.	Check installation against design.
	Minimum set speed setting incorrect.	Adjust as necessary.
	Incorrect pressure sensor setting.	Adjust sensor screw as necessary.
	Faulty Fan Speed Controller.	Replace controller and sensor (as they are matched sets).
	Faulty pressure sensor.	Replace controller and sensor (as they are matched sets).
Condenser fans runs only slowly	Incorrect pressure setting.	Adjust sensor screw as necessary.
	Faulty Controller.	Replace controller and sensor (as they are matched sets).
	Faulty Pressure sensor.	Replace controller and sensor (as they are matched sets).
	Motor/capacitor faulty.	Replace.

Maintenance

IMPORTANT The equipment contains live electrical and moving parts, isolate all electrical equipment before any work is carried out.

ACCESS Access to the compressor and control panel area is gained by removing the securing screws from the cover of the condensing unit casing and lifting the cover off.
Access is gained to the fan(s) through the top of the unit by removing the top cover.

MAINTENANCE SCHEDULE

3 MONTHS At every service visit the following checks should be carried out:-

Fan & Motor Assembly

- CU./CUH. 1-12**
- 1 Examine the fan and motor assembly for lateral and end play in the bearings.
 - 2 Examine the electrical gland plate to ensure that no water is entering the motor.
 - 3 Examine the fan blades for damage and corrosion.

CFCUS5 - 10 Check condition, tension and alignment of drive belt(s). Adjust or replace as necessary. Lubricate damper pivots if required.

Refrigeration Circuits

- 1 Visually examine pipework and components for damage, wear and tear and oil patches, the latter being indicative of a system leak.
- 2 Check the suction and discharge pressures using a service gauge manifold and compare them with the commissioning sheet. If there is any significant variation, then the fault should be found and corrected. Refer to **Troubleshooting**.
- 3 Check that the high and low pressure switches (if fitted) are cutting out the compressor(s) at the commissioned settings.
- 4 Ensure the fan head pressure controller is controlling the head pressure at the required setting as indicated on the commissioning sheets provided.

The gauges can then be removed from the system. Do not forget to replace the security caps on the Schrader valves.

Condenser coil

Clean the condenser coil with a stiff bristled hand brush. If dirt has accumulated over a long period, or tends to be greasy or sticky, then it may be necessary to use a water hose or chemical pressure hose. Take care not to damage the fins and comb out if they have become damaged in any way.

IMPORTANT Do not use steam for cleaning condenser coils otherwise damage or danger may result from excessive internal pressures

Cabinet Wash down cabinet using a mild detergent. Treat any paint damage or rust as necessary.

- Electrical**
- 1 Check all electrical connections for signs of overheating or arcing.
 - 2 Check all cables for signs of chafing or physical damage.

12 MONTHS As per 3 months plus:

- 1 Check all electrical connections for security.
- 2 Check all refrigeration connections with a leak detector.

Notes:



Head Office:

Airedale International Air Conditioning Ltd

Leeds Road
Rawdon
Leeds LS19 6JY
United Kingdom

Tel: +44 (0) 113 239 1000

Fax: +44 (0) 113 250 7219

e-mail: enquiries@airedale.com

website: www.airedale.com



PART NO:	ISSUE	DATE
904-038 IM E	A	01/11/00
	B	01/01/03
	C	01/03/03

Airedale Departmental Contact Details:

CUSTOMER SERVICES For further assistance, please e-mail: enquiries@airedale.com or telephone:

UK Sales Enquiries	+ 44 (0) 113 238 7789	uk.sales@airedale.com
International Enquiries	+ 44 (0) 113 239 1000	enquiries@airedale.com
Spares Hot Line	+ 44 (0) 113 238 7878	spares@airedale.com
Airedale Service	+ 44 (0) 113 239 1000	service@airedale.com
Technical Support	+ 44 (0) 113 239 1000	tech.support@airedale.com
Training Enquiries	+ 44 (0) 113 239 1000	marketing@airedale.com

For information, visit us at our Web Site: www.airedale.com