

## Contents

<b>GENERAL DESCRIPTION</b>	<b>2</b>
Introduction	2
Construction	2
<b>CAPACITY DATA</b>	<b>4</b>
Cooling Duty - Cooling Only Units	4
Cooling Duty – Reverse Cycle Mode	4
Heating Duty - Reverse Cycle Mode	5
<b>OPERATING DATA</b>	<b>6</b>
Operating Limits - Cooling Only	6
<b>DIMENSIONS: CUS/CUHS 5 - 7.5</b>	<b>7</b>
<b>DIMENSIONS: CUS/CUHS 10 - 12</b>	<b>7</b>
<b>TECHNICAL DATA</b>	<b>8</b>
<b>ELECTRICAL DATA</b>	<b>9</b>
<b>NOISE DATA</b>	<b>10</b>
<b>FIELD CONNECTIONS</b>	<b>11</b>

**General Description**

**UNIT IDENTIFICATION**

AIR COOLED CONDENSING UNIT & OUTDOOR HEAT PUMP RANGE	
<b>CUS</b> .....	Condensing Unit Cooling Only
<b>CUHS</b> .....	Outdoor Heat Pump
<b>5-12</b> .....	Model Size
<b>e.g.</b> .....	<b>Model CUS 6</b>

**INTRODUCTION**

This range of air cooled condensing units and heat pumps covers the 14-35kW requirement, in axial fan only.

The range is custom designed for use with Airedale's comprehensive range of close control units and Comfort Modular units. They can also be used in conjunction with other cooling applications, eg air handling units. All units are leak tested and carry a holding charge of inert gas.

**CONSTRUCTION**

The units are constructed of corrosion resistant pre-coated sheet steel. Standard unit colour is Light Grey (RAL 7035).

**CONDENSER**

Large surface area condenser coil(s) manufactured from refrigeration quality copper tubes, with mechanically bonded aluminium fins.

**FAN**

610mm diameter axial flow fan assembly(s) with low noise paddle type blades. The external rotor motor design allows the use of a low power output single phase speed controllable motor. The motor has inbuilt thermal overload protection, and the assembly is supplied complete with a finger guard for protection.

**COMPRESSOR**

All units utilise hermetic scroll compressors. The CUS7.5/10 and 12 models are fitted with a crankcase heater to guard against floodback and oil foaming on start up. Other features include internal motor protection.

**REFRIGERATION**

**Cooling Only**

Each unit is fitted with a liquid and suction line shut off valve for ease of maintenance and installation. Factory set HP/LP pressure switches are fitted, with manual reset high pressure cut-out and automatic reset low pressure cut-out.

A large capacity filter drier is supplied loose for on site installation.

## REFRIGERATION

### Heat Pump

Each unit is fitted with a thermostatic expansion valve and a check valve assembly to prevent short circuiting of refrigerant, together with a large capacity suction accumulator and a reversing valve. A factory set defrost switch facilitates defrosting of the outside coil when in heat pump mode. All heat pump compressors are fitted with crankcase (oil sump) heaters.

Factory set HP/LP pressure switches are fitted, with manual reset high pressure cut-out and automatic reset low pressure cut-out.

A bi-directional filter drier is supplied loose for on site installation.

## ELECTRICAL

Weatherproof control panels are accessed via a lockable panel and contain the necessary contactors, sub-circuit protection and terminals .

All wiring is colour coded and numbered for identification. All units are wired in accordance with current local and European standards.

## HEAD PRESSURE CONTROL

Head pressure is maintained by a factory fitted, pressure actuated head pressure controller which varies the speed of the fan to provide optimum head pressure control under varying ambient conditions.

## MAINS ISOLATOR

A weatherproof mains isolator is fitted to ensure mains isolation of the electrical panel.

## OPTIONS

### Epoxy Coated Coils

In atmospheres where high corrosion is anticipated epoxy coated aluminium finned coils can be supplied.

### Hot Gas Bypass (Cooling Only Units)

To achieve capacity control during low load conditions, a factory fitted hot gas bypass valve is fitted. This will modulate down to 40% of full capacity. A stub is provided for site connection of the hot gas line to the local expansion device.

### Compressor Anti-Cycle Timer

To prevent short cycling and subsequent additional wear on the compressor, this option can be factory fitted to limit compressor starts to six per hour. Not required on Airedale equipment featuring start delay timers inbuilt into the Air Handling unit.

### Defrost Drain Tray (Heat Pump Only)

An insulated and trace heated drain tray can be provided to collect condensate when units are used in the reverse cycle/defrost mode.

Capacity Data

COOLING DUTY - COOLING ONLY UNITS

	Evaporating Temperature °C	Ambient									
		25°C		30°C		35°C		40°C		45°C	
		Output kW	Input kW	Output kW	Input kW	Output kW	Input kW	Output kW	Input kW	Output kW	Input kW
CUS5	-5	10.83	2.65	10.21	3.07	9.61	3.49	9.06	3.91	8.40	4.33
	0	12.99	2.88	12.28	3.28	11.57	3.67	10.89	4.07	10.21	4.50
	5	15.26	3.13	14.48	3.51	13.73	3.89	12.95	4.27	12.17	4.72
	10	17.64	3.43	16.82	3.80	16.00	4.17	15.16	4.54	14.35	4.99
CUS6	-5	14.31	4.00	13.60	4.54	12.88	5.07	12.16	5.61	11.21	6.21
	0	17.09	4.30	16.16	4.81	15.23	5.32	14.28	5.84	13.31	6.46
	5	19.86	4.60	18.87	5.11	17.90	5.62	16.84	6.18	15.57	6.75
	10	22.86	4.93	21.81	5.43	20.77	5.94	19.57	6.51	18.43	7.07
CUS7.5	-5	16.67	4.81	15.79	5.47	14.86	6.12	13.96	6.77	12.98	7.49
	0	19.85	5.08	18.83	5.71	17.84	6.36	16.84	7.00	15.64	7.76
	5	23.39	5.39	20.21	6.00	21.04	6.60	19.81	7.26	18.57	7.99
	10	27.19	5.67	25.89	6.24	24.58	6.82	23.14	7.54	21.78	8.19
CUS10	-5	22.15	5.27	20.88	6.21	19.66	7.14	18.41	8.07	17.17	9.01
	0	26.12	5.56	24.90	6.47	23.61	7.38	22.38	8.29	21.12	9.22
	5	33.92	5.94	30.66	6.73	27.41	7.52	24.14	8.30	21.79	9.17
	10	35.89	6.14	34.60	7.00	33.32	7.87	31.98	8.73	30.52	9.69
CUS12	-5	28.25	7.81	26.80	8.83	25.35	9.86	23.94	10.89	22.38	11.97
	0	33.54	8.35	31.95	9.32	30.30	10.30	28.69	11.27	26.87	12.35
	5	39.30	8.85	37.52	9.82	35.73	10.79	33.91	11.78	31.86	12.89
	10	45.68	9.53	43.74	10.14	41.78	10.74	39.62	11.98	37.23	13.37

COOLING DUTY - REVERSE CYCLE MODE

	Evaporating Temperature °C	Ambient									
		25°C		30°C		35°C		40°C		45°C	
		Output kW	Input kW	Output kW	Input kW	Output kW	Input kW	Output kW	Input kW	Output kW	Input kW
CUHS5	-5	10.40	2.54	9.80	2.95	9.23	3.35	8.70	3.75	8.06	4.16
	0	12.47	2.76	11.79	3.15	11.11	3.52	10.45	3.91	9.80	4.32
	5	14.65	3.00	13.90	3.37	13.18	3.73	12.43	4.10	11.68	4.53
	10	16.93	3.29	16.15	3.65	15.36	4.00	14.55	4.36	13.78	4.79
CUHS6	-5	13.74	3.84	13.06	4.36	12.36	4.87	11.67	5.39	10.76	5.96
	0	16.41	4.13	15.51	4.62	14.62	5.11	13.71	5.61	12.78	6.20
	5	19.07	4.42	18.12	4.91	17.18	5.40	16.17	5.93	14.95	6.48
	10	21.95	4.73	20.94	5.21	19.94	5.70	18.79	6.25	17.69	6.79
CUHS7.5	-5	16.00	4.62	15.16	5.25	14.27	5.88	13.40	6.50	12.46	7.19
	0	19.06	4.88	18.08	5.48	17.13	6.11	16.17	6.72	15.01	7.45
	5	22.45	5.17	19.40	5.76	20.20	6.34	19.02	6.97	17.83	7.67
	10	26.10	5.44	24.85	5.99	23.60	6.55	22.21	7.24	20.91	7.86
CUHS10	-5	21.29	5.06	20.06	5.97	18.89	6.86	17.69	7.76	16.50	8.66
	0	25.10	5.34	23.93	6.22	22.69	7.09	21.51	7.97	20.30	8.86
	5	32.60	5.71	29.46	6.47	26.34	7.23	23.20	7.98	20.94	8.81
	10	34.49	5.90	33.25	6.73	32.02	7.56	30.73	8.39	29.33	9.31
CUHS12	-5	27.15	7.51	25.75	8.49	24.36	9.48	23.01	10.47	21.51	11.50
	0	32.23	8.02	30.70	8.96	29.12	9.90	27.57	10.83	25.82	11.87
	5	37.77	8.50	36.06	9.44	34.34	10.37	32.59	11.32	30.62	12.39
	10	43.90	9.16	42.03	9.74	40.15	10.32	38.07	11.51	35.78	12.85

Notes:

- 1 Output kW refers to the compressor duty.
- 2 Input kW refers to the compressor input power only

## Capacity Data

### HEATING DUTY - REVERSE CYCLE MODE

Outdoor Unit Evaporator Air On Temperature °C/ RH %	Indoor Unit Condensing Temperature						
	30°C Output kW	35°C Output kW	40°C Output kW	45°C Output kW	50°C Output kW	55°C Output kW	
<b>CUHS5</b>	5 / 85	14.24	14.07	14.01	13.93	13.84	13.75
	7 / 85	15.30	15.07	14.98	14.88	14.71	14.58
	10 / 80	16.40	16.30	16.09	15.90	15.70	15.55
<b>CUHS 6</b>	5 / 85	18.65	18.60	18.64	18.61	18.57	18.49
	7 / 85	19.78	19.71	19.69	19.58	19.49	19.31
	10 / 80	21.40	21.17	21.14	20.93	20.65	20.41
<b>CUHS 7.5</b>	5 / 85	22.16	22.01	21.94	21.89	21.75	21.69
	7 / 85	23.45	23.24	23.20	23.02	22.95	22.90
	10 / 80	25.38	25.24	25.15	24.93	24.74	24.58
<b>CUHS 10</b>	5 / 85	25.66	25.40	25.15	24.90	24.65	24.40
	7 / 85	27.19	26.92	26.65	26.38	26.12	25.86
	10 / 80	29.37	29.08	28.79	28.50	28.21	27.93
<b>CUHS 12</b>	5 / 85	29.16	28.87	28.58	28.29	28.01	27.73
	7 / 85	30.90	30.59	30.29	29.98	29.68	29.39
	10 / 80	33.38	33.05	32.72	32.39	32.06	31.74

Notes:

- 1 Output kW refers to the compressor duty.
- 2 Indoor ambient at 20°C

**Operating Data**

**OPERATING LIMITS - COOLING ONLY**

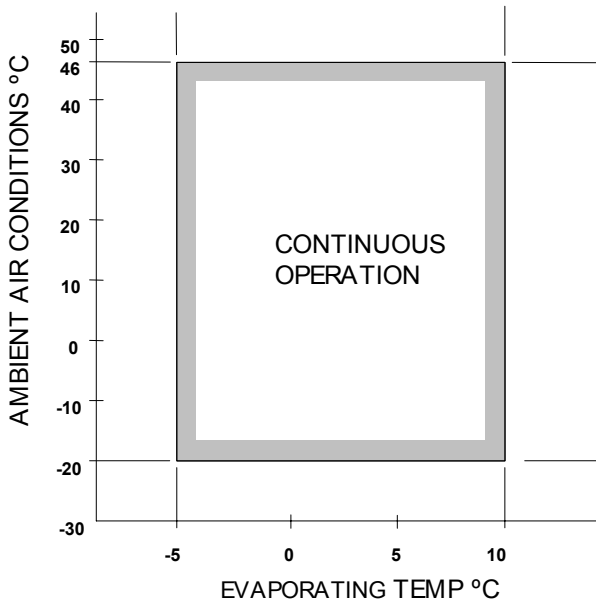

**OPERATING LIMITS - HEAT PUMP**

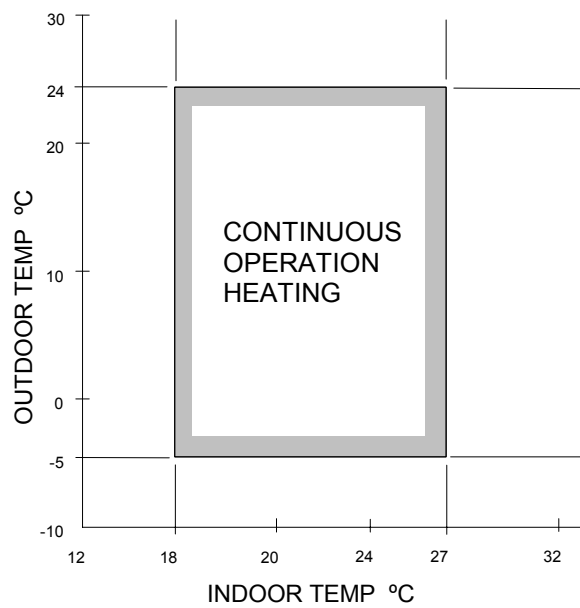
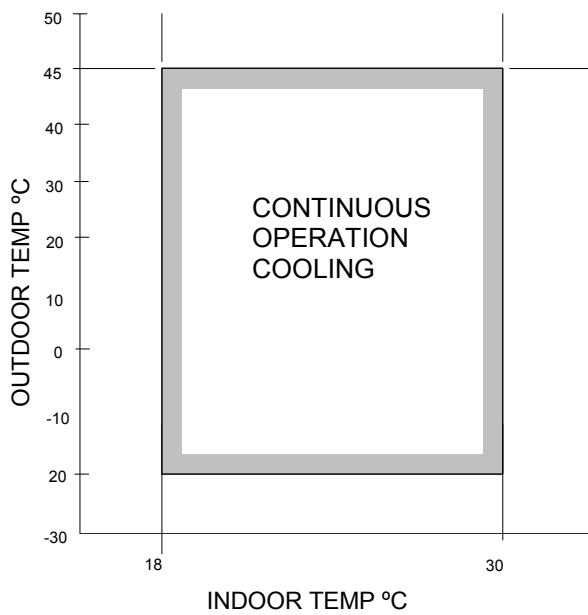

## Dimensions: CUS/CUHS 5 - 7.5

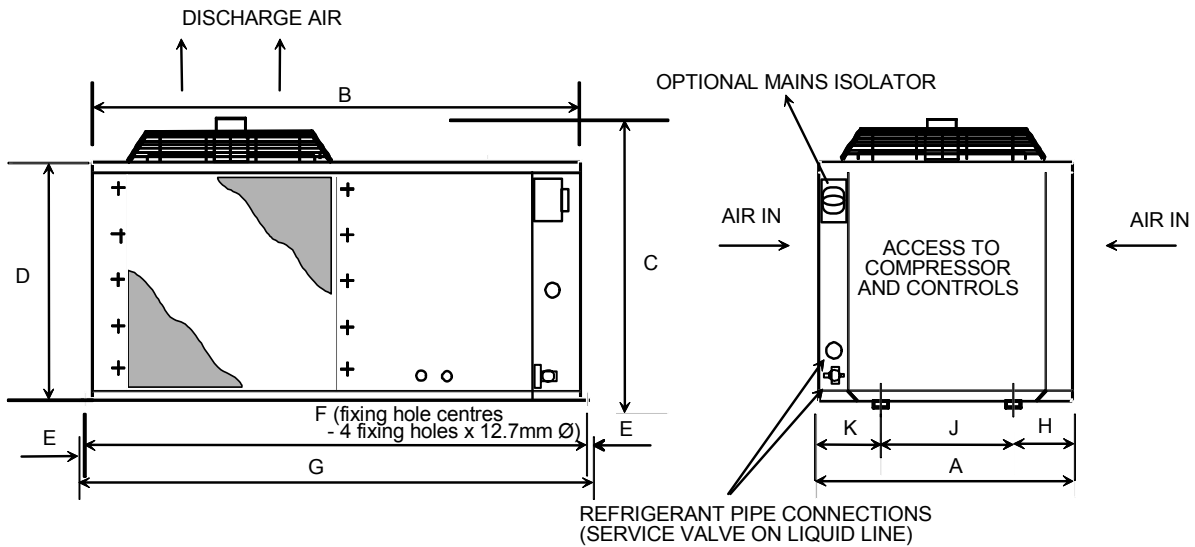

CUS/CUHS		A	B	C	D	E	F	G	H	J	K
5	mm	865	1148	699	550	16	1181	1213	195	457	213
6	mm	865	1148	699	550	16	1181	1213	195	457	213
7.5	mm	996	1376	699	550	16	1409	1441	193	610	193

## Dimensions: CUS/CUHS 10 - 12

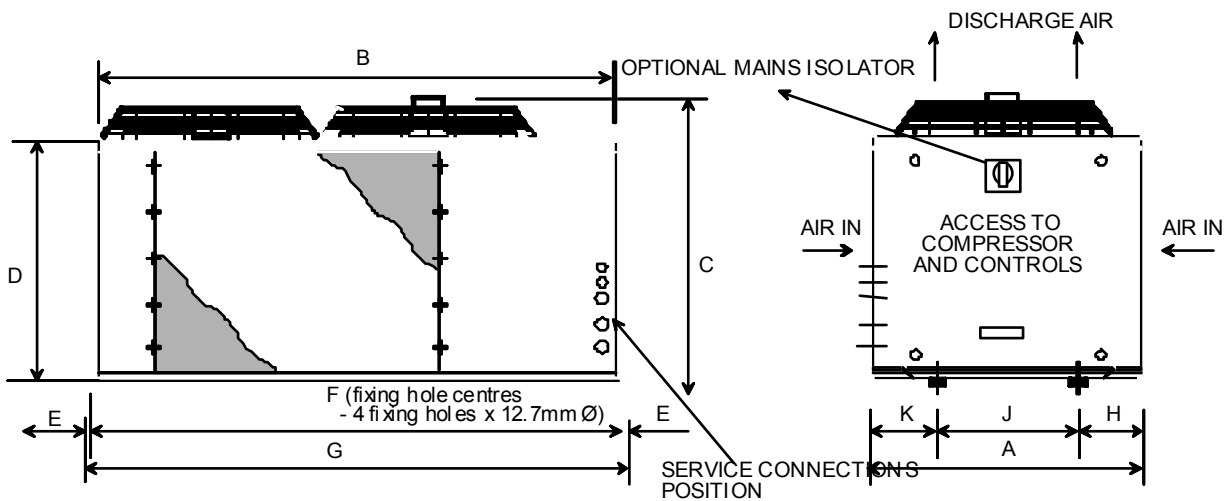

CUS/CUHS		A	B	C	D	E	F	G	H	J	K
10	mm	866	1705	953	810	16	1738	1770	204	457	204
12	mm	866	1705	953	810	16	1738	1770	204	457	204

### Notes:

- 1 Incoming Services: Connections to left hand side of unit compressor compartment.
- 2 Airflow and Maintenance Clearance: Please allow 500mm around the unit for airflow and maintenance purpose.

Technical Data

CUS/CUHS		5	6	7.5	10	12
<b>Nominal Capacity</b> (1)	kW	13.7	17.9	21.0	27.4	35.7
<b>Nominal Input</b> (1)	kW	5.1	6.4	6.6	10.0	11.5
Capacity Steps	%	0-100	0-100	0-100	0-100	0-100
<b>Construction</b>						
Material		Pre Coated Sheet Steel				
Colour		Light Grey (RAL 7035)				
<b>Condenser</b>						
Type		Air Cooled				
Quantity		2	2	3	2	2
Face Area	m <sup>2</sup>	0.69	0.69	1.03	1.37	1.37
Nominal Airflow	m <sup>3</sup> /s	2.00	2.00	2.25	4.45	4.45
Coil Volume (2)	l	8.0	8.0	12.0	15.7	15.7
Discharge		Vertical				
<b>Fan</b>						
Type		Axial				
Quantity		1	1	1	2	2
Diameter	mm	610	610	610	610	610
Maximum Speed	rpm	930	930	930	930	930
<b>Compressor</b>						
Type		Hermetic Scroll				
Quantity		1	1	1	1	1
Oil Charge Volume	L	1.55	1.65	3.25	3.80	4.00
<b>Refrigeration</b>						
Number of Circuits		1	1	1	1	1
Refrigerant Type		R407C				
Refrigeration Control (CUH only)		Thermostatic Expansion Valve				
Unit Refrigerant Charge	kg	2.4	2.4	3.63	4.76	4.76
<b>Dimensions</b>						
Height	mm	699	699	699	953	953
Width	mm	1148	1148	1376	1705	1705
Depth	mm	865	865	996	866	866
<b>Weights CUS Units</b>						
Machine Weight (nom)	kg	138	141	203.5	242	247
Operating Weight (nom)	kg	141	144	208.5	261	266
<b>Weights CUHS Units</b>						
Machine Weight (nom)	kg	164	167	216.5	267	272
Operating Weight (nom)	kg	168	171	222.5	272	277
<b>Connections</b>						
Liquid Line	in	Flare 1/2	Flare 5/8	Flare 5/8	Sweat 7/8	Sweat 7/8
Suction Line	in	Sweat 7/8	Sweat 7/8	Sweat 1 1/8	Sweat 1 1/8	Sweat 1 3/8
Hot Gas Stub	in	5/8	5/8	5/8	7/8	7/8

- (1) Nominal cooling capacity based on 5°C evaporating temperature and a 35°C ambient.
- (2) Figures for guidance.

## Electrical Data

CUS/CUHS		5	6	7.5	10	12
<b>Unit Data</b>						
Nominal Run Amps (1)	A	11.4	13.5	15.2	21.1	26.6
Maximum Start Amps	A	68.3	100.8	103.8	131.6	186.6
Control Circuit CUS	VAC	230	230	230	230	230
Control Circuit CUHS	VAC	24	24	24	24	24
Mains Supply	V	400/3/50				
Rec. Mains Fuse	A	20	25	32	40	40
Max Incoming Mains	mm <sup>2</sup>	10	10	10	10	10
<b>Compressor</b>						
Motor Rating	kW	4.5	5.9	6.9	8.9	11.6
Nominal Run Amps (1)	A	8.9	11.0	12.7	16.1	21.6
Locked Rotor Amps	A	62.5	95.0	98.0	120.0	135.0
Crankcase Heater Rating	W	65 <sup>(2)</sup>	65 <sup>(2)</sup>	50	50	50
Type of Start		Direct on Line				
<b>Condenser Fan</b>						
Motor Rating	kW	0.55	0.55	0.55	0.55	0.55
Full Load Amps	A	2.50	2.50	2.50	2.50	2.50
Locked Rotor Amps	A	5.80	5.80	5.80	5.80	5.80

- (1) Nominal data based on 5°C evaporating temperature and a 35°C ambient.  
 (2) Heat pumps only.

**Noise Data**

Sound Pressure Measurement	dBa	Frequency (Hz)							
		63	125	250	500	1000	2000	4000	8000
<b>CUS/CUHS 5 - 6</b> @ 1 m	71	72	73	71	70	68	60	53	46
@ 10 m	51	52	53	51	50	48	40	33	26
<b>CUS/CUHS 7.5</b> @ 1 m	73	73	71	74	71	69	64	57	50
@ 10 m	53	53	51	54	51	49	44	37	30
<b>CUS/CUHS 10-12</b> @ 1 m	73	80	77	73	72	69	63	56	47
@ 10 m	53	60	57	53	52	49	43	36	27

Note: Above noise levels are with the condenser fan running at full speed. Under normal operating conditions (ambients up to 35°C) noise levels will be reduced by 3 - 4 dB.

## Field Connections

<b>CUS 5-12</b>	L1	○	➔	Mains Incoming 400/3/50		
	L2	○				
	L3	○				
	N	○				
	E	○				
<b>CUS 5-12</b>	576	○	➔	576/577 Cooling Signal from AHU (24vac)		
	577	○				
	589	○			➔	589/502 Volt Free Contacts For Trip Indication
	502	○				
<b>CUHS 5-12</b>	L1	○	➔	Mains Incoming 400/3/50		
	L2	○				
	L3	○				
	N	○				
	E	○				
	504	○	➔	Cooling Signal from AHU 24vac		
	502	○				
	523	○	➔	Defrost Signal to AHU AHU Fan Running Heating Signal from AHU		
	517	○				
	515	○				
	500	○	➔	0 vac		
	589	○				
	590	○				
			➔	589/590 Volt Free Contact for Trip Indication		

## About Airedale

### WARRANTY, COMMISSIONING & MAINTENANCE

As standard, Airedale guarantees all non consumable **parts only** for a period of **24 months**, variations tailored to suit product and application are also available, please contact Airedale for full terms and details.

To further protect your investment in Airedale products, we have introduced Airedale Service, who can provide full commissioning services, comprehensive maintenance packages and service cover 24 hours a day, 365 days a year (UK mainland). For a free quotation contact our Airedale Service or your local Sales Engineer.

**CAUTION**  **Warranty cover is not a substitute for Maintenance. Warranty cover is conditional to maintenance being carried out in accordance with the recommendations provided during the warranty period. Failure to have the maintenance procedures carried out will invalidate the warranty and any liabilities by Airedale International Air Conditioning Ltd.**

### SPARES

A spares list for 1, 3 and 5 years will be supplied with every unit and is also available from our Spares department on request.

### TRAINING

As well as our comprehensive range of products, Airedale offers a modular range of Refrigeration and Air Conditioning Training courses, for further information please contact our Training Co-ordinator.

# Airedale Departmental Contact Details:

**CUSTOMER SERVICES** For further assistance, please e-mail: [enquiries@airedale.com](mailto:enquiries@airedale.com) or telephone:

<b>UK Sales Enquiries</b>	+ 44 (0) 113 238 7789	<a href="mailto:uk.sales@airedale.com">uk.sales@airedale.com</a>
<b>International Enquiries</b>	+ 44 (0) 113 239 1000	<a href="mailto:enquiries@airedale.com">enquiries@airedale.com</a>
<b>Spares Hot Line</b>	+ 44 (0) 113 238 7878	<a href="mailto:spares@airedale.com">spares@airedale.com</a>
<b>Airedale Service</b>	+ 44 (0) 113 239 1000	<a href="mailto:service@airedale.com">service@airedale.com</a>
<b>Technical Support</b>	+ 44 (0) 113 239 1000	<a href="mailto:tech.support@airedale.com">tech.support@airedale.com</a>
<b>Training Enquiries</b>	+ 44 (0) 113 239 1000	<a href="mailto:marketing@airedale.com">marketing@airedale.com</a>

For information, visit us at our Web Site: [www.airedale.com](http://www.airedale.com)



**Head Office:**

**Airedale International Air Conditioning Ltd**

Leeds Road  
Rawdon  
Leeds LS19 6JY  
United Kingdom

**Tel: +44 (0) 113 239 1000**

**Fax: +44 (0) 113 250 7219**

**e-mail: [info@airedale.com](mailto:info@airedale.com)**

**website: [www.airedale.com](http://www.airedale.com)**

A  **MODINE** Company

AIAC Ltd endeavours to ensure that the information in this document is correct and fairly stated, but none of the statements are to be relied upon as a statement or representation of fact. AIAC Ltd does not accept liability for any error or omission, or for any reliance placed on the information contained in this document.

The development of Airedale products and services is continuous and the information in this document may not be up to date. It is important to check the current position with AIAC Ltd at the address stated. This document is not part of a contract or licence unless expressly agreed.

No part of this document may be reproduced or transmitted in any form or by any means, electronic or mechanical, including photocopying, recording, or information storage and retrieval systems, for any purpose other than the purchaser's personal use, without the express written permission of AIAC Ltd.

© 2002 Airedale International Air Conditioning Limited. All rights reserved.

## **SUBJECT: Global Changes to Airedale range of Air Conditioning Units**

The following statements outline global changes made to the full range of Airedale International Air Conditioning Ltd products and supersede ALL other dated material contained within this manual, quotations and posted to the Airedale.com website:

1. The standard unit colour of all Airedale Manufactured products is Light Grey RAL 7035 (This excludes, Aerovent, Ecotel Outdoor and Cassettes).
2. Units constructed with metal panels are made from Galvanised sheet steel coated with a durable and weatherproof finish.
3. ALL units are run on R407C as standard, R22 is only available as an option to Countries outside the EU.

Literature will be updated to reflect these changes in due course.