



# Ecotel Outdoor Upflow Telecom Unit

TCU5 - TCU19D  
5KW - 19KW



## TECHNICAL MANUAL



ISO 14001  
EM552086



ISO 9001  
FM00542

## About Airedale Products & Customer Services

### WARRANTY, COMMISSIONING & MAINTENANCE

As standard, Airedale guarantees all non consumable **parts only** for a period of **24 months**, variations tailored to suit product and application are also available, please contact Airedale for full terms and details.

To further protect your investment in Airedale products, we have introduced Airedale Service, who can provide full commissioning services, comprehensive maintenance packages and service cover 24 hours a day, 365 days a year (UK mainland). For a free quotation contact our Airedale Service or your local Sales Engineer.

All Airedale products are designed in accordance with EU Directives regarding prevention of build up of water, associated with the risk of contaminants such as Legionella.

Where applicable, effective removal of condensate is achieved by gradient drainage to outlets and where used, humidification systems produce sterile, non-toxic steam during normal operation.

For effective prevention of such risk it is necessary that the equipment is maintained in accordance with Airedale recommendations.

### CAUTION

**Warranty cover is not a substitute for Maintenance. Warranty cover is conditional to maintenance being carried out in accordance with the recommendations provided during the warranty period. Failure to have the maintenance procedures carried out will invalidate the warranty and any liabilities by Airedale International Air Conditioning Ltd.**

### SPARES

A spares list for 1, 3 and 5 years will be supplied with every unit and is also available from our Spares department on request.

### TRAINING

As well as our comprehensive range of products, Airedale offers a modular range of Refrigeration and Air Conditioning Training courses, for further information please contact Airedale.

AIAC Ltd endeavours to ensure that the information in this document is correct and fairly stated, but none of the statements are to be relied upon as a statement or representation of fact. AIAC Ltd does not accept liability for any error or omission, or for any reliance placed on the information contained in this document.

The development of Airedale products and services is continuous and the information in this document may not be up to date. It is important to check the current position with AIAC Ltd at the address stated. This document is not part of a contract or licence unless expressly agreed.

No part of this document may be reproduced or transmitted in any form or by any means, electronic or mechanical, including photocopying, recording, or information storage and retrieval systems, for any purpose other than the purchaser's personal use, without the express written permission of AIAC Ltd.

© 2003 Airedale International Air Conditioning Limited. All rights reserved. Printed in the UK.

## Contents

<b>GENERAL DESCRIPTION</b>	<b>4</b>
Unit Identification	4
Introduction	4
Standard Features	4
Optional Extras - General	6
Optional Extras - Controls	7
<b>GENERAL SPECIFICATION</b>	<b>8</b>
Mechanical Data	8
Electrical Data	9
<b>PERFORMANCE DATA</b>	<b>10</b>
Capacity Data	10
Sound Data	11
<b>INSTALLATION DATA</b>	<b>12</b>
Dimensions (mm)	12
Weights (kg)	12
Drainage	13
Mounting	13
<b>DESIGN DATA</b>	<b>14</b>
Unit Operation	14
Interconnecting Wiring	14
<b>CONTROLS</b>	<b>15</b>
Standard Features	15
Optional Features	15
Alarms	16
Operation	17
Operating Limits	17

## General Description

### UNIT IDENTIFICATION

UPFLOW - ECOTEL OUTDOOR UNIT	
<b>TCU</b>	Upflow Telecom Communication Unit
<b>5 - 19</b>	Model Sizes (Nominal kW)
<b>D</b>	Dual Circuit
<b>XQ</b>	Extra Quiet Unit
<b>Example</b>	<b>Model TCU15D</b>

### INTRODUCTION

This self-contained packaged air conditioning unit is purpose built for Outdoor Telecom applications, including cabins, shelters and base stations and is available in 6 model capacity sizes and suitable for single or 3 phase electrical supplies.

The unit is externally mounted and utilises single or dual circuit refrigeration systems to provide 1, 2 or 3 stages of cooling. Single circuit units comprise of 5kW, 8kW, 11kW and 15kW. Double circuit units include 15kW and 19kW. All models have 1 free cooling stage. Units are configured for upflow applications. As standard the unit controller offers an additional energy saving feature by shutting off the evaporator fans at low room temperatures.

Each unit is pre charged with R407C, factory piped, wired to current EU standards, performance, leak and function tested prior to despatch.

The unit is despatched having been pre-commissioned ready for offering up to the appropriate services.

### CE DIRECTIVE

 Airedale certify that the equipment detailed in this manual conforms with the following EC Directives:

Electromagnetic Compatibility Directive (EMC)	<b>89/336/EEC (EN61000-6-4 : 2001 &amp; EN61000-6-2 : 2001)</b>
Low Voltage Directive (LVD)	<b>73/23/EEC</b>
Machinery Directive (MD)	<b>89/392/EEC in the version 98/37/EC</b>
Pressure Equipment Directive (PED)	<b>97/23/EC</b>

To comply with these directives appropriate national & harmonised standards have been applied. These are listed on the Declaration of Conformity, supplied with each product.

### STANDARD FEATURES

#### Construction

Unit cabinets are manufactured from galvanised sheet steel coated with epoxy baked powder paint to provide a durable and weatherproof finish.

Cabinets are lined internally with fire resistant foam (UL94 VO) for thermal and acoustic insulation.

Standard unit colour is Grey (RAL 7038).

Vandal proof fixings are employed to all externally removable service panels and the unit has a pitched roof to prevent water and snow collecting.

#### Evaporator

Large surface area coil(s) ideally positioned to optimise airflow and heat transfer, manufactured from refrigeration quality copper tubes with mechanically bonded aluminium fins.

#### Condenser

Large surface area coil(s) ideally positioned to optimise airflow and heat transfer, manufactured from refrigeration quality copper tubes with mechanically bonded aluminium fins.

## General Description

### Fan & Motor Assembly

#### Evaporator

Backward curved centrifugal fans, statically and dynamically balanced for efficient and quiet operation.

Each fan motor has in-built thermal overload protection.

Fan speed is microprocessor controlled.

#### Condenser

The unit utilises sickle bladed axial flow fan(s) for the benefit of low noise characteristics. The unique external rotor motor design allows the use of a low power output single phase speed controllable motor to power the fan. The motor has in-built thermal overload protection, and the assembly is supplied complete with a finger guard for protection.

#### Compressor

Hermetic scroll compressors fitted as standard with:

- Compressor(s) are mounted to the base via the use of vibration isolators.
- Internal thermal motor protection.

#### Refrigeration

Each refrigeration circuit features as standard:

- Externally equalised thermostatic expansion valve
- High pressure switch - automatic
- Low pressure switch - automatic
- Operating R407C Refrigerant charge
- Filter drier
- Sight glass

#### Filtration

Synthetic disposable panel filters in a rigid frame to BS EN 779 - G4.

Wire framed synthetic cleanable pre filters to BS EN 779 - G2.

An adjustable diaphragm pressure switch is fitted across the filter assembly to monitor pressure drop which will initiate a filter dirty alarm.

#### Electrical

The control panel is situated on the front of the unit behind the access panel. The access panel is hinged and supported by lockable door stays to provide a weather hood during servicing.

#### Controls

**AIRTEC** microprocessor controlled:

- TCU 5,8,11 & 15 operating 1 stage of DX cooling and 0-100% Free Cooling
- TCU 15D & TCU19D operating 3 stages of DX cooling and 0-100% free cooling
- Monitoring and Alarm Indication via optional Display.

For full details, please refer to the [Controls](#) section.

#### Outside Air Damper

The unit is fitted with an electrically controlled, modulating damper capable of supplying 100% fresh air into the room as "free cooling". The damper may be automatically modulated to any position to allow mixing of the return air and outside air before being supplied to the conditioned space.

The damper has a manual operation facility.

The minimum set point for the fresh air damper is fully adjustable via the optional remote display keypad.

#### Indoor Air Pressure Relief

This is achieved when the unit is in free cooling mode by exhausting air over the condenser coil and through the condenser section.

#### Non Vision Grilles

Anodised aluminium construction, supplied loose for on site fitting.

#### Fixing Tool

As standard each unit is supplied with a tamperproof fixing tool, additional tools are available.

## General Description

### OPTIONAL EXTRAS - GENERAL

<b>Extra Quiet</b>	Extra quiet unit for low noise applications, incorporates staged condenser and evaporator fan speeds with head pressure control and compressor acoustic jackets to minimise noise.
<b>Epoxy Coated Coils</b>	In atmospheres where high corrosion is anticipated epoxy coated aluminium finned coils can be supplied for the evaporator and condenser sections.
<b>Heating Options</b>	Finned electric heating element(s) complete with overheat cut out protection. Also incorporated is a factory fitted panel interlock device which de-activates the unit upon the control panel door being opened.
<b>High Efficiency Filters</b>	Synthetic disposable panel filters in a rigid frame to BS EN 779 - F5.
<b>Shut off Damper</b>	Additional damper assembly to close off return and supply air openings to the conditioned space in the event of smoke or fire being detected. (Not fire/smoke rated)
<b>Double Deflection Discharge Air Grille</b>	Anodised aluminium construction, to manually adjust direction of airflow, supplied loose for on site fitting.
<b>External Mounting Rails</b>	As standard units are supplied with internal fixings, optional external mountings can be factory fitted if required.
<b>Roof Flashing Strip</b>	Supplied loose for on site fitment to provide further weatherproofing.
<b>48V dc Emergency Power Operating System</b>	This option utilises a 48Vdc control circuit. If power should fail to the mains circuits the clients own UPS or battery system will maintain the 48Vdc control Circuit, enabling the 48Vdc evaporator fans and damper to provide 'Free Cooling'.
<b>Electronic Soft Start</b>	An electronic soft starter can be fitted to each compressor. Soft starting a compressor motor reduces the effects of high starting torque surges. Available in single and 3 phase.
<b>Single Phase Unit</b> (Except Model TCU15)	If required, units can be supplied as 230V/1PH+N/50Hz.
<b>Maintenance 13A Socket</b>	Single 13A socket for unit maintenance only.
<b>Head Pressure Control</b>	Head pressure is maintained by a factory fitted, pressure actuated, head pressure controller which varies the speed of the condenser fan(s) to provide optimum control under varying ambient conditions.
<b>Panel Interlock</b>	Factory fitted, the unit will de-activate upon the control panel door being opened.
<b>Phase Sequence Relay</b>	A phase failure relay can be fitted to shut down the system, upon sensing abnormality in the 3 phase sequence.

## General Description

### OPTIONAL EXTRAS - CONTROLS

<b>User Display</b>	Remote display can be installed inside the conditioned space or loose for hand held use, which can monitor temperatures, alarms, hours run and adjust setpoints.
<b>Remote On/Off</b>	An electrical contact is provided for connection to a remote unit ON/OFF device (supplied by others).
<b>Real Time Clock</b>	A real time clock plug-in card is available for energy savings and will time / date stamp any alarms.
<b>BMS Communication</b>	<p>With use of communication plug-in cards, the <del>AIAT</del>Tronix microprocessor can also communicate with the following control protocols, Carel, ModBus / Jbus Echelon LONWorks, Johnson Metasys and Trend.</p> <p>The BMS can monitor remotely, Temperatures, Alarms, Hours run and adjust Setpoints; can be viewed using a PC via a PSTN / GSM modem connection.</p>
<b>Run/Standby</b>	Up-to 6 units can be networked to provide run / standby, changing over on hours run and critical alarms.
<b>Master/Slave</b>	Up-to 6 units can be networked to provide master/slave, with an optional standby unit changing over on hours run, critical alarms.
<b>Attend/Occupancy Mode</b>	To allow reduction of evaporator fan speed during 'Attend Mode' and to allow reduction of airflow during low temperature conditions (< 10°C conditioned space temperature).

## General Specification

### MECHANICAL DATA

TCU		5	8	11	15	15D	19D
<b>Capacity - Nom Cooling</b>							
Total	(1) kW	5.4	8.2	11.0	16.0	15.3	22.5
Sensible	(1) kW	4.4	7.1	10.6	15.2	14.4	19.3
EER		3.4	2.8	3.2	3.2	3.4	2.6
Capacity Steps	%	0 & 100	0 & 100	0 & 100	0 & 100	0, 30, 70 & 100	0, 40, 60 & 100
<b>Dimensions</b>							
H x W x D	mm	1588 x 1005 x 565			2038 x 1365 x 565		
<b>Weights</b>							
Machine	kg	210	215	276	281	292	398
Operating	kg	212	217	280	285	296	400
<b>Construction</b>							
Material / Colour		Galvanised Sheet Steel, Epoxy Baked Powder Paint- Light Grey (RAL 7038)					
<b>Evaporator</b>							
		Copper Tubes / Aluminium Fins - Air Cooled					
Quantity		1	1	1	1	1	1
Face Area	m <sup>2</sup>	0.30	0.30	0.73	0.73	0.73	0.75
Nominal Airflow	m <sup>3</sup> /s	0.45	0.75	0.95	1.20	1.20	1.15
Discharge		Horizontal					
<b>Condenser</b>							
		Copper Tubes / Aluminium Fins – Air Cooled					
Quantity		1	1	1	1	1	1
Face Area	m <sup>2</sup>	0.35	0.35	0.60	0.60	0.60	0.71
Nominal Airflow	m <sup>3</sup> /s	1.10	1.10	1.80	2.00	2.00	2.00
Discharge		Horizontal					
<b>Fan - Evaporator</b>							
		Backward Curved Centrifugal					
Quantity		2	2	2	2	2	2
Diameter	mm	310	310	355	355	355	400
Maximum Speed	rpm	1430	1430	1430	1430	1430	1360
<b>Fan - Condenser</b>							
		Axial					
Quantity		1	1	2	2	2	2
Diameter	mm	450	450	400	450	450	450
Maximum Speed	rpm	1400	1400	1430	1400	1400	1310
<b>Compressor</b>							
		Hermetic – Scroll					
Quantity		1	1	1	1	2	2
Oil Charge Volume (Total)	l	1.0	1.1	1.8	1.85	1.00 & 1.10	1.1 & 1.95
Oil Type		Polyol Ester					
<b>Refrigeration</b>							
		Single Circuit			Dual Circuit		
Refrigeration Control		Thermostatic Expansion Device					
Refrigerant Type		R407C					
Charge (Total)	kg	2.0	2.0	2.3	3.98	2.0 & 3.0	2.0 & 3.7
<b>Filtration</b>							
		Disposable - BS EN 779 – G2 & BS EN 779 - G4					
Quantity		1+1	1+1	2 + 2	2 + 2	2 + 2	1 + 1
Size H x W x D	mm	624 x 395 x 5 & 624 x 395 x 47		448 x 448 x 5 & 448 x 448 x 47		1100x395x5 & 1100x395x47	
<b>Optional Extras</b>							
Heating	kW	2.5	2.5	5.0	5.0	5.0	5.0
High Efficiency Filters		BS EN 779 – F5					

(1) Nominal Cooling Duties based on 27°C db/19°C wb and 35°C ambient.

## General Specification

### ELECTRICAL DATA

TCU		5	8	11	15	15D	19D
<b>Electrical Supply Data</b>							
Nominal Run Amps	(1) A	4.6	6.8	8.5	11.4	10.9	18.7
Maximum Start Amps	(1) A	27.8	49.8	56.0	81.1	56.1	87.8
Recommended Mains Fuse	(1) A	10	16	16	20	16	25
Max Mains Incoming Cable Size	(1) mm <sup>2</sup>	1.50	1.50	1.50	2.50	1.50	4.0
Mains Supply		400V / 3PH + N / 50Hz					
Controls Circuit	Vac	24	24	24	24	24	24
<b>Evaporator Fan - per Fan (2)</b>							
Quantity		2	2	2	2	2	2
Motor Rating	W	120	120	210	210	210	415
Full Load Amps	A	0.54	0.54	0.97	0.97	0.97	2.00
Locked Rotor Amps	A	1.62	1.62	2.91	2.91	2.91	6.00
<b>Condenser Fan - per Fan (2)</b>							
Quantity		1	1	2	2	2	2
Motor Rating	W	292	292	204	245	245	610
Full Load Amps	A	1.1	1.1	0.91	1.1	1.1	2.8
Locked Rotor Amps	A	3.3	3.3	2.73	3.3	3.3	8.4
<b>Compressor 1 - per Compressor</b>							
Motor Rating	kW	1.6	2.9	3.4	4.9	1.6	2.4
Nominal Run Amps	A	2.9	5.2	6.2	8.7	2.9	4.54
Locked Rotor Amps	A	24.0	46.0	50.0	74.0	24.0	40.0
Type of Start		Direct on Line					
<b>Compressor 2 - per Compressor</b>							
Motor Rating	kW	N/A	N/A	N/A	N/A	2.9	4.2
Nominal Run Amps	A	N/A	N/A	N/A	N/A	5.2	8.0
Locked Rotor Amps	A	N/A	N/A	N/A	N/A	46.0	66.0
Type of Start		Direct on Line					
<b>OPTIONAL EXTRAS</b>							
<b>Heating</b>							
Unit Run Amps with Elec Htg	A	10.87	10.87	21.74	21.74	21.74	21.74
Electric Heater Rating	kW	2.5	2.5	5.0	5.0	5.0	5.0
Number of Stages		1	1	1	1	1	1
Number of Elements		1	1	2	2	2	2
<b>Electronic Compressor Soft Start</b>							
Reduced Start 3Ph Compressor 1	(3) A	14.2	28.3	30.6	45.8	14.2	24.0
Reduced Start 3Ph Compressor 2	(3) A	N/A	N/A	N/A	N/A	28.3	39.6
Reduced Start 1Ph Compressor 1	(3) A	25.9	55.0	62.2	N/A	25.9	N/A
Reduced Start 1Ph Compressor 2	(3) A	N/A	N/A	N/A	N/A	55.0	N/A
<b>Client's 48Vdc Emergency Power</b>							
Nominal Run Amps	A	5.90	5.90	5.90	16.30	16.30	20.2
<b>Single Phase Unit</b>							
Nominal Run Amps	(1) A	10.3	16.3	21.3	N/A	25.9	N/A
Maximum Start Amps	(1) A	51.9	104.9	120.9	N/A	112.3	N/A
Recommended Mains Fuse	(1) A	16	32	35	N/A	40.0	N/A
Max Mains Incoming Cable Size	(1) mm <sup>2</sup>	1.5	4.0	6.0	N/A	6.0	N/A
Mains Supply		230V/1PH+N/50Hz					
Controls Voltage	Vac	24	24	24	N/A	24	N/A
<b>Compressor 1 - per Compressor</b>							
Motor Rating	kW	1.6	2.9	3.5	N/A	1.6	N/A
Nominal Run Amps	A	7.6	13.6	17.1	N/A	7.6	N/A
Locked Rotor Amps	A	47.0	100.0	113.0	N/A	47.0	N/A
Type of Start		Direct on Line					
<b>Compressor 2 - per Compressor</b>							
Motor Rating	kW	N/A	N/A	N/A	N/A	2.9	N/A
Nominal Run Amps	A	N/A	N/A	N/A	N/A	13.6	N/A
Locked Rotor Amps	A	N/A	N/A	N/A	N/A	100.0	N/A
Type of Start		Direct on Line					

- (1) Cooling only unit (based at 35°C ambient and 50°C condensing temperature).  
 (2) Includes pressure drops.  
 (3) 3Ph Electronic Soft Start based on 40% Reduction In Compressor Starting Current.  
 1Ph Electronic Soft Start based on 45% Reduction In Compressor Starting Current.

## Performance Data

### CAPACITY DATA

DX Cooling Capacity Air On °C db/50% RH		Ambient							
		25°C		30°C		35°C		40°C	
		TC (kW)	SC (kW)	TC (kW)	SC (kW)	TC (kW)	SC (kW)	TC (kW)	SC (kW)
TCU5	22	5.2	4.4	5.0	4.3	4.8	4.2	4.5	4.1
	24	5.5	4.5	5.3	4.4	5.0	4.3	4.7	4.2
	27	5.9	4.6	5.7	4.5	5.4	4.4	5.1	4.3
TCU8	22	8.1	7.2	7.7	6.9	7.2	6.7	6.4	6.4
	24	8.6	7.3	8.1	7.1	7.6	6.9	6.6	6.5
	27	9.2	7.4	8.6	7.2	8.2	7.1	7.2	6.7
TCU11	22	11.4	10.6	10.8	10.3	10.2	10.1	9.7	9.5
	24	11.9	10.8	11.3	10.6	10.7	10.3	10.1	9.9
	27	12.8	11.1	12.2	10.9	11.0	10.6	10.8	10.4
TCU15	22	16.0	15.1	15.2	14.8	14.4	14.0	13.7	13.3
	24	16.7	15.4	15.9	15.1	15.0	14.9	14.2	14.1
	27	17.8	15.9	16.9	15.6	16.0	15.2	15.0	14.9
TCU15D	22	14.6	14.4	14.0	13.8	13.8	13.4	12.7	12.4
	24	15.4	14.7	14.7	14.4	14.2	13.9	13.3	13.3
	27	16.6	15.8	15.8	15.6	15.3	14.4	14.4	14.4
TCU19D	22	21.9	18.7	20.9	18.4	20.0	18.3	19.4	17.0
	24	23.0	18.9	22.0	18.5	20.9	18.8	20.3	18.3
	27	24.8	20.2	23.7	19.8	22.5	19.3	21.2	19.0

Free Cooling Capacity (Gross) Air On 24°Cdb/50% RH		Ambient			
		13.5°C TC (kW)	15.0°C TC (kW)	19.0°C TC (kW)	20.0°C TC (kW)
TCU5		4.8	4.1	2.3	0.9
TCU8		8.0	6.9	3.8	1.5
TCU11		10.2	8.7	4.8	1.9
TCU15		12.9	11.0	6.1	2.4
TCU15D		12.9	11.0	6.1	2.4
TCU19D		12.9	11.0	6.1	2.4

TC = Total Cooling SC = Sensible Cooling

## Performance Data

**SOUND MEASUREMENT** All sound data quoted has been measured in the third-octave band, limited values using a Real Time Analyser calibrated sound intensity meter in accordance with BS ISO9614 (Part 1) : 1995.

- 1 Sound Power Levels calculated from measured sound intensity according to BS EN ISO9614 Part 1 : 1995.
- 2 dB(A) is the overall sound level, measured on the A scale.
- 3 Sound Pressure Levels calculated from sound power using the semi-hemispherical method according to BS EN ISO11203 : 1996. If the equipment is placed adjacent to a reflective wall, values may vary to those stated in our Performance Data section, typically you can add 3dB(A) for each side added.
- 4 The above data is based on unit typical running conditions.

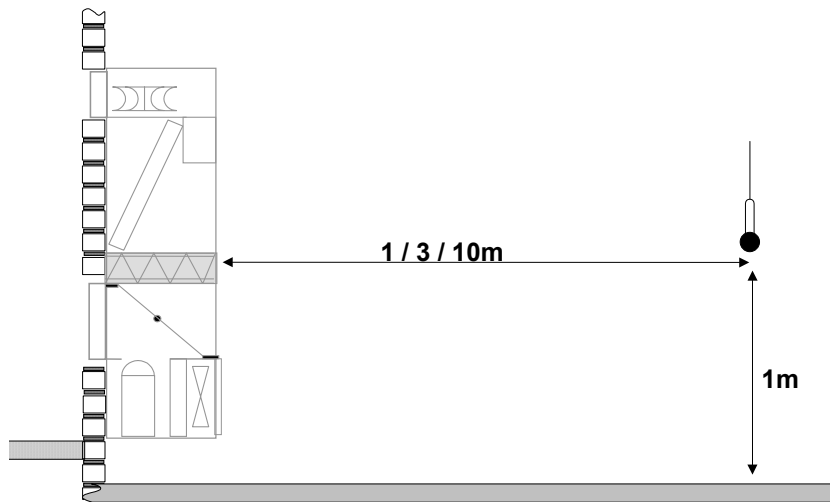

## SOUND DATA

Sound Measurement	Nominal Operation (dBA)		XQ Unit (dBA) <sup>(1)</sup>	
	Free Cooling	DX	DX	
<b>TCU5</b>	Power	47	78	71
	Pressure @ 1m	45	73	66
	Pressure @ 3m	35	63	56
	Pressure @ 10m	25	53	46
<b>TCU8</b>	Power	47	78	72
	Pressure @ 1m	45	73	67
	Pressure @ 3m	35	64	57
	Pressure @ 10m	25	53	47
<b>TCU11</b>	Power	70	79	72
	Pressure @ 1m	65	74	67
	Pressure @ 3m	55	64	57
	Pressure @ 10m	45	54	47
<b>TCU15</b>	Power	70	81	73
	Pressure @ 1m	65	75	69
	Pressure @ 3m	55	66	59
	Pressure @ 10m	45	55	49
<b>TCU15D</b>	Power	70	81	73
	Pressure @ 1m	65	75	69
	Pressure @ 3m	55	66	59
	Pressure @ 10m	45	55	49
<b>TCU19D</b>	Power	74	90	80
	Pressure @ 1m	69	84	72
	Pressure @ 3m	59	74	62
	Pressure @ 10m	49	64	52

(1) This option utilises fan speed regulation to indoor and outdoor fans and a compressor acoustic jacket.

## Installation Data

### DIMENSIONS (mm)

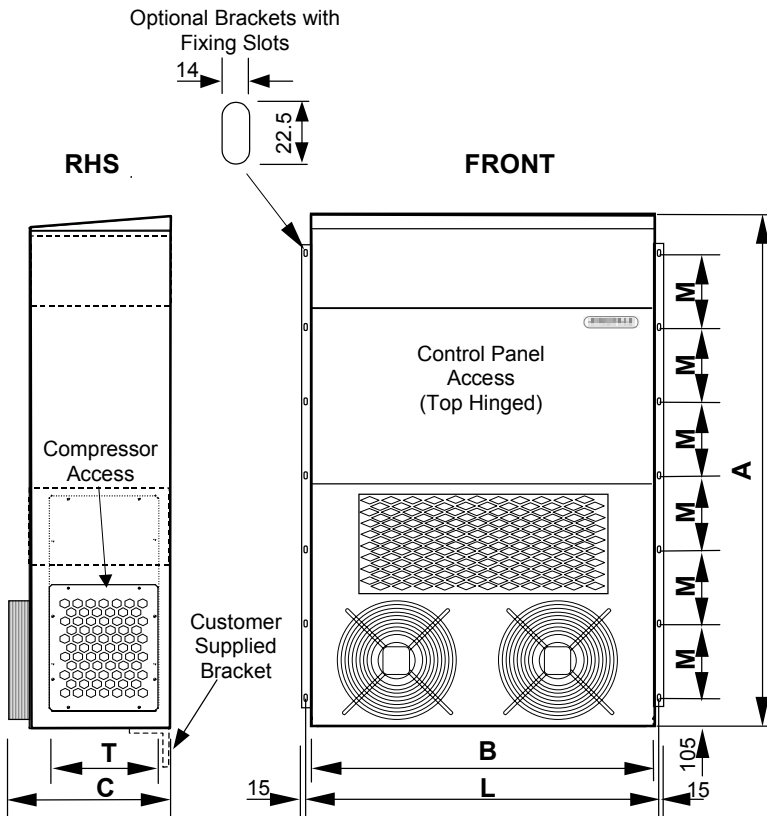

### WEIGHTS (kg)

		Operating
TCU5	kg	212
TCU8	kg	217
TCU11	kg	280
TCU15	kg	285
TCU15D	kg	296
TCU19D	kg	400

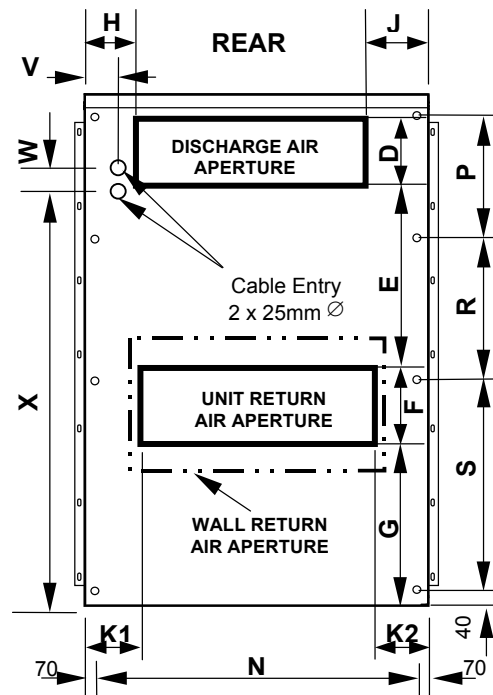

		A	B	C	D	E	F	G	H	J
TCU5	mm	1588	1005	650	200	552	250	535	177	228
TCU8	mm	1588	1005	650	200	552	250	535	177	228
TCU11	mm	2038	1365	600	263	768	325	633	296	269
TCU15 & TCU15D	mm	2038	1365	600	263	768	325	633	296	269
TCU19D	mm	2038	1365	661	263	768	325	633	296	269

		K1	K2	L	M	N	P	R	S	T
TCU5	mm	203	203	1030	675 x 2	866	500	462	500	320
TCU8	mm	203	203	1030	675 x 2	866	500	462	500	320
TCU11	mm	283	283	1395	300 x 6	1225	540	580	802	430
TCU15 & TCU15D	mm	283	283	1395	300 x 6	1225	540	580	802	430
TCU19D	mm	185	34	1395	300 x 6	1225	540	580	802	430

		Mains Incoming Hole Positions			Cabin/Wall Apertures*		Unit Apertures	
		V	W	X	Discharge	Return Air	Discharge	Return Air
TCU5	Mm	61	55	1354	600 x 200	600 x 410	600 x 200	600 x 250
TCU8	Mm	61	55	1354	600 x 200	600 x 410	600 x 200	600 x 250
TCU11	Mm	155	55	1883	800 x 263	800 x 480	800 x 263	800 x 325
TCU15 & TCU15D	Mm	155	55	1883	800 x 263	800 x 480	800 x 263	800 x 325
TCU19D	Mm	155	55	1883	800 x 263	1146 x 480	800 x 263	1146 x 325

1 The cabin/wall apertures are to be cut central to the unit apertures.

## Installation Data

### LIFTING/POSITIONING

- Remove packing and check that the unit is exactly as ordered. Any discrepancy to order, or transit damage, should be reported to Airedale immediately.
- Airedale recommends that whenever possible, the packaging is left covering the unit, to protect it from damage and general site debris.
- This small footprint unit is relatively tall and heavy. Care should be taken during handling and lifting, that the unit is well supported and properly balanced.
- Care should be taken that there are no obstructions to free airflow, particularly in the vicinity of the condenser fan discharge (outdoor) and also the return / discharge air (indoor).
- Where a cavity wall exists between AHU and conditioned space, a wall sleeve will be required. (Supplied by others).

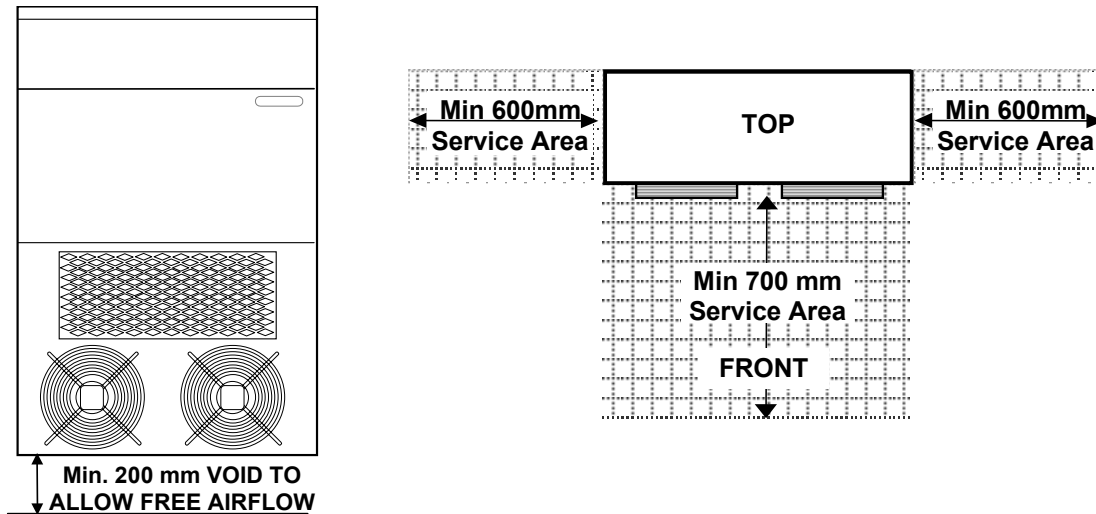

**CAUTION** ▼ Airedale will accept no responsibility for mishandling during the positioning of the equipment.

### DRAINAGE

Each module has condensate drain(s) exiting from the base of the unit which should be clear of obstructions.

The unit condensate drain trap(s) accessible through the unit side panel(s), require filling to be fully effective. Water should be added to the drain until water discharges from the condensate outlet.

### MOUNTING

**CAUTION** ▼ Units **MUST** be supported by a 3" cabin mounted angle iron (not supplied).

## Design Data

### UNIT OPERATION

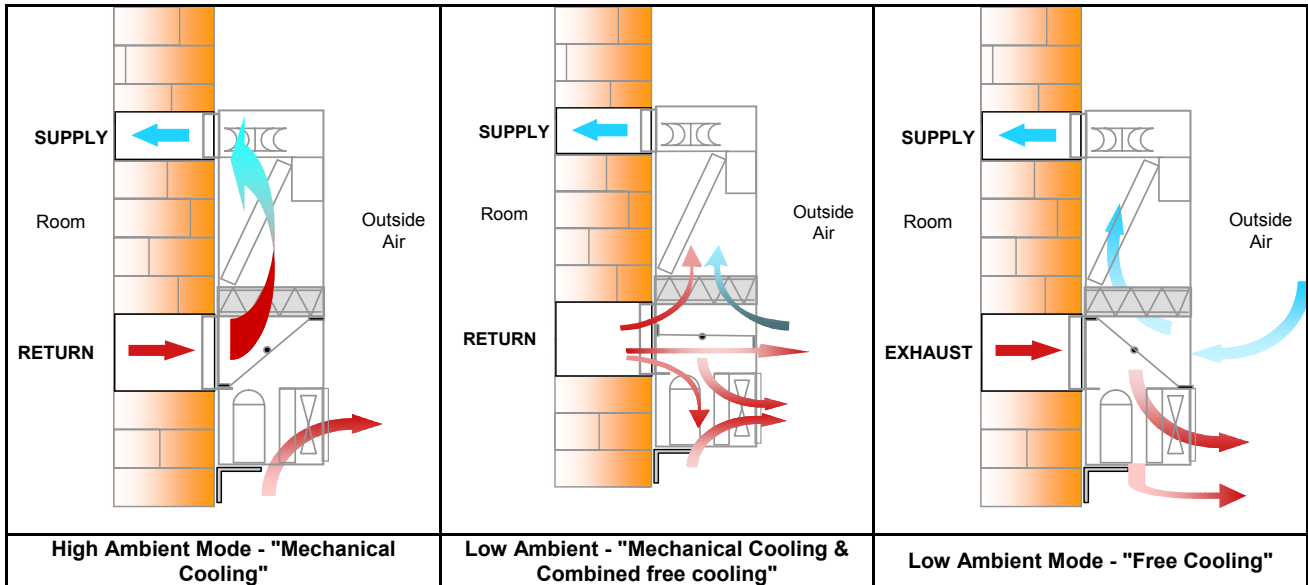

### INTERCONNECTING WIRING

TCU 5-19D	L1	○	← Mains Incoming Supply 400V/3PH+N/50Hz ± 10% or 230V/3PH+N/50Hz
	L2	○	
	L3	○	
	N	○	
	PE	○	
	502	○	← Auxiliary Alarm
	524	○	
	560	○	} Volt Free Alarms Open On Fail
	561	○	
	562	○	
	563	○	
	564	○	
	565	○	→
	Rx-/Tx-	○	↔ Network Connection used for Run/Standby or Master/Slave
	Rx+/Tx+	○	
GND	○		

## Controls

### GENERAL

As standard the units are fitted with an **AIRETronix** microprocessor controller, with optional Real Time Clock (RTC), RS232 communication port, networking capability and BMS connection. An optional LCD remote display provides all the necessary functions for the wide range of features and options available. The LCD display provides audible and visual monitoring of the unit operation.

The LCD display is mounted remotely.

With use of optional communication plug-in cards, the **AIRETronix** microprocessor can also communicate with the following control protocols, Carel, ModBus / Jbus Echelon LONWorks, Johnson Metasys and Trend.

The **AIRETronix** microprocessor controller has been specifically designed to provide the control information necessary to operate the unit in an energy efficient manner.

The unit will operate in 1 of 4 modes:

- 1 Free Cooling - using outside air only
- 2 Free Cooling and DX Cooling - using outside air and DX cooling
- 3 DX Cooling - mechanical cooling with room return air
- 4 Electric Heating (Optional Extra)

### TEMPERATURE CONTROL

The **AIRETronix** microprocessor senses the Return Air condition and maintains this by controlling cooling and heating (Optional) outputs accordingly.

The **AIRETronix** microprocessor monitors and displays the following measured parameters:

- Return Air Temperature
- Exterior Air Temperature
- Evaporator Coil Temperature
- Compressor 1 (2) Liquid Line Pressure (Head Pressure Control Option)
- Alarms Reset
- Attend Mode or Remote On/OFF (Optional)
- Overheat Cut-Out (Electric Heat Option)
- Airflow Switch
- Filter Switch
- Compressor 1 (Compressor 2) MCB
- Condenser Fan MCB
- Evaporator Fan MCB
- Compressor 1 (Compressor 2) Low Pressure Switch
- Compressor 1 (Compressor 2) High Pressure Switch
- Auxiliary Alarm (Smoke/Fire/Panel Interlock)

### STANDARD FEATURES

#### Compressor Anti-Cycle Control

Automatic compressor protection via the microprocessor.

#### Evaporator Fan Speeds

Varying speeds can be configured for heating, 1, 2 or 3 DX stages, free cooling and speed at temperature setpoint.

#### Hours Run

Calculates hours run of major components.

#### Maintenance Overrides

Allows testing of major components.

### OPTIONAL FEATURES

- User Display
- Real Time Clock
- Password Protection
- Remote On/Off
- Head Pressure Control
- Master/Slave Networking
- Run/Standby Networking
- Attend/occupancy Mode
- Duty Rotation Networking

## AIRETronix - Controls

### OPTIONAL GRAPHICAL DISPLAY

(Shown with Keypad Lid Open)



### ALARMS

Outlined below is a selection of Common Alarms:

- Room Air Temperature out of limits or faulty probe
- Exterior Air Temperature out of limits or faulty probe
- Frost Protection or faulty probe
- Compressor 1(2) Liquid Line Pressure out of limits or faulty probe (Head Pressure Control option)
- Overheat Cut-out tripped (Electric Heat option)
- Air Flow Switch tripped
- Filter Dirty Switch tripped
- Compressor 1(2) MCB tripped
- Condenser Fan MCB tripped
- Evaporator Fan MCB tripped
- Compressor 1(2) Low Pressure Switch tripped
- Compressor 1(2) High Pressure Switch tripped
- Auxiliary Alarm tripped (Smoke/Fire/Panel Interlock)

An **Audio-Visual** alarm will be triggered at the optional display keypad.

### ALARMS LOG

The controller logs and allows viewing of the last 100 conditions recorded in descending chronological order through the optional keypad display.

## AIRETronix - Controls

### OPERATION

#### Single Circuit Unit

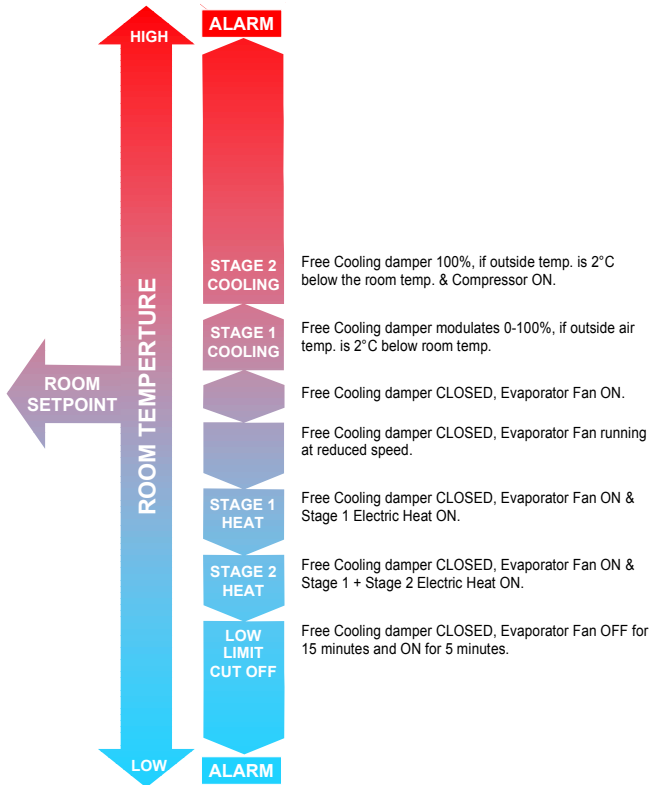

#### Double Circuit Unit

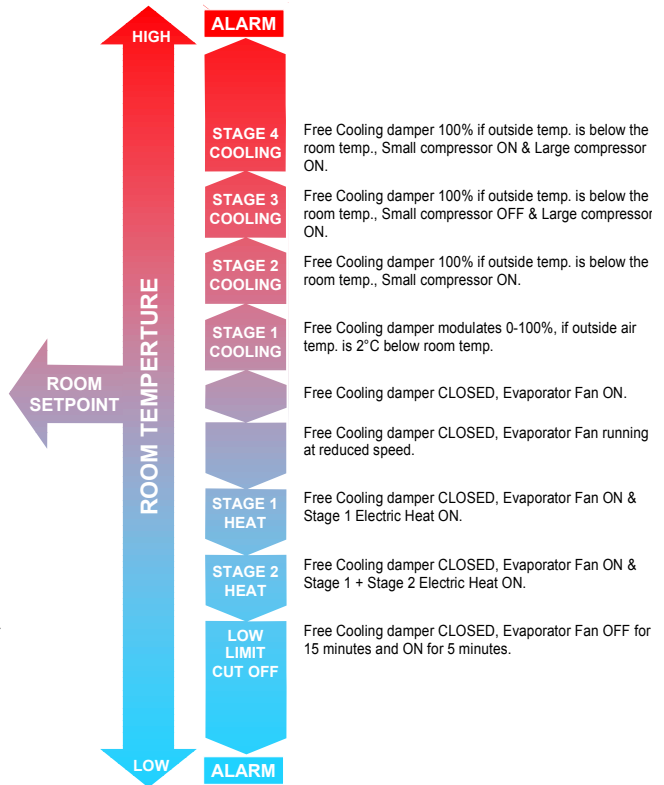

### OPERATING LIMITS

	CONDITIONED SPACE TEMPERATURE	UNIT OPERATION
TCU5 - TCU15	Less than 18°C	Damper is closed
	Between 18°C and 21°C	Fresh air damper modulates
	23°C	Circuit 1 (5kW, 8kW, 11kW & 15kW cooling) is active
	35°C	Over temperature alarm is generated
TCU15D – TCU19D	Less than 18°C	Damper is closed
	Between 18°C and 21°C	Fresh air damper modulates
	21°C	Circuit 1 (1 <sup>st</sup> stage compressor) is active
	23°C	Circuit 2 (2 <sup>nd</sup> stage compressor) is active
	25°C	Circuits 1 & 2 (combined 1 <sup>st</sup> & 2 <sup>nd</sup> stage compressors) are active
	35°C	Over temperature alarm is generated

- 1 The damper also assists mechanical cooling when the outdoor air is less than 2°C below the return air temperature.
- 2 When the outdoor ambient is below 13.5°C the DX Cooling will not operate.
- 3 When conditioned area is below 14°C the evaporator fans will switch off to conserve energy.
- 4 All microprocessor settings are adjustable via the user display.



**Head Office:**

**Airedale International Air Conditioning Ltd**  
Leeds Road  
Rawdon  
Leeds LS19 6JY  
United Kingdom

**Tel:** +44 (0) 113 239 1000  
**Fax:** +44 (0) 113 250 7219

**e-mail:** [info@airedale.com](mailto:info@airedale.com)  
**website:** [www.airedale.com](http://www.airedale.com)



<b>PART NO:</b>	<b>ISSUE</b>	<b>DATE</b>
901-063 TM E	A	<del>01/06/01</del>
	B	<del>11/07/01</del>
	C	<del>26/10/01</del>
	D	<del>29/11/01</del>
	E	<del>17/04/02</del>
	F	18/06/03

# Airedale Departmental Contact Details:

**CUSTOMER SERVICES** For further assistance, please e-mail: [enquiries@airedale.com](mailto:enquiries@airedale.com) or telephone:

<b>UK Sales Enquiries</b>	+ 44 (0) 113 238 7789	<a href="mailto:uk.sales@airedale.com">uk.sales@airedale.com</a>
<b>International Enquiries</b>	+ 44 (0) 113 239 1000	<a href="mailto:enquiries@airedale.com">enquiries@airedale.com</a>
<b>Spares Hot Line</b>	+ 44 (0) 113 238 7878	<a href="mailto:spares@airedale.com">spares@airedale.com</a>
<b>Airedale Service</b>	+ 44 (0) 113 239 1000	<a href="mailto:service@airedale.com">service@airedale.com</a>
<b>Technical Support</b>	+ 44 (0) 113 239 1000	<a href="mailto:tech.support@airedale.com">tech.support@airedale.com</a>
<b>Training Enquiries</b>	+ 44 (0) 113 239 1000	<a href="mailto:marketing@airedale.com">marketing@airedale.com</a>

For information, visit us at our Web Site: [www.airedale.com](http://www.airedale.com)