

## INSTALLATION & SUBMITTAL DATA

### 7-day/24 hour programmable time clock with power-outage gas-fired duct furnace/make-up air units model series: “D”, “H”, “I”, & “O”

#### **⚠ WARNING**

1. Disconnect power supply before making wiring connections to prevent electrical shock and equipment damage.
2. All units must be wired strictly in accordance with wiring diagram furnished with the unit. Any wiring different from the wiring diagram could result in a hazard to persons and property.
3. All wiring must be done with a wiring material having a temperature rating of at least 105°C.

#### **IMPORTANT**

The use of this manual is specifically intended for a qualified installation and service agency. All installation and service of these units must be performed by a qualified installation and service agency. Modine manuals may contain excerpts from component supplier literature adapted for Modine products. Any accompanying component supplier literature is for general information.

#### **Application**

The EC7000 Series Electronic Time Control is a single channel, 7-day/24-hour digital programmable clock/controller that features 7-day power-outage carryover of program and time of day without the use of batteries. The control allows for simple and inexpensive control of functions such as automatic temperature setback (requires setback thermostat purchased separately), reduction of outside air during periods when the building is not occupied, and switching main supply fans from continuous to intermittent operation.

As a 24-hour control, the same ON/OFF program is utilized each day of the week, Saturday and/or Sunday, or any other day may be skipped. When schedules vary from day to day, the 7-day programming capability allows for a different schedule each day of the week, with up to 16 setpoints available.

**Figure 1.1**  
**EC7000 Time Clock**



#### **Component**

EC7000/120V  
 Operating Temperature Range: -40 to +140°F  
 Operating Humidity Range: 0 - 95%, non-condensing  
 Operating Voltage: 120VAC  
 Frequency: 50/60Hz  
 Power Consumption: 4VA  
 Wiring Terminals: #16 to #10 AWG wire  
 UL Listed, CSA Certified, and complies with FCC rules.  
 Case: NEMA 1 drawn steel enclosure with lockable hasp  
 The unit is to be mounted indoors in an environment free of excessive contaminants such as oil, moisture, and dirt.

Output Switch Ratings (SPDT relay contacts):  
 \* Normally Open and Normally Closed Contacts:  
 20A resistive (10A CSA) at 24-240VAC  
 1Hp (1/2Hp CSA) at 120VAC, 2Hp (1Hp CSA) at 240VAC

Selectable Clock Format: 12 hour (AM/PM) or 24 hour  
 Min. ON or OFF Time: 1 minute  
 Max. ON or OFF Time: 6 days, 23 hours, and 59 minutes  
 Power Outage Carry-Over Duration: 7 days minimum  
 Display: Digital

## Definitions

### Setpoint

A setpoint defines the time and day(s) for which an event is to occur and the event (ON or OFF). When the setpoint day/time is reached, the controller will change the state of the relay contacts as programmed.

### Manual Override

The manual override feature allows for reversal of the current output state. The override begins immediately when initiated and remains until overridden again or until the next setpoint is reached.

### Power Outage Carry-Over

The power outage carry-over feature allows for power to be interrupted to the controller for a minimum of 7 days without losing the program or time of day information. The controller uses a built-in capacitor, eliminating inconvenient and environmentally hazardous batteries.

## Installation

The EC7000 is housed in a NEMA 1 drawn steel enclosure with lockable hasp. The unit is to be mounted indoors in an environment free of excessive contaminants such as oil, moisture, and dirt. Mounting holes are provided in the rear of the enclosure for mounting to a wall, terminal box, etc. Conduit entrance knockouts are provided on the sides, bottom, and rear of enclosure.

## Wiring

# IMPORTANT

All line and low voltage wiring to time clock must be suitable for line voltage in compliance with NEC requirements for separation of circuits.

Installation of wiring must conform with local building codes, or in the absence of local codes, of the National Electric Code ANSI/NFPA 70 - Latest Edition. Unit must be electrically grounded in conformance to this code. In Canada, wiring must comply with CSA C22.1, Part 1, Electrical Code.

The terminals for supply power and relay contacts will accommodate #16 to #10 AWG copper wire.

The relay contacts on the controller do not power the load. Input power supplied to the controller enables the time and program information to be kept and program operations to be executed. However, the contacts act as switches only, power must be supplied to operate the load.

## Wiring Diagram Selection

- For duct furnaces (non-factory supplied blower) refer to the following figures for wiring.
- For system units (factory supplied blower) refer to the job specific unit-wiring diagram provided with the unit.
- For deviations to these wiring diagrams or the job specific wiring diagrams: consult the factory.

Figure 2.1

### Typical Duct Furnace Wiring

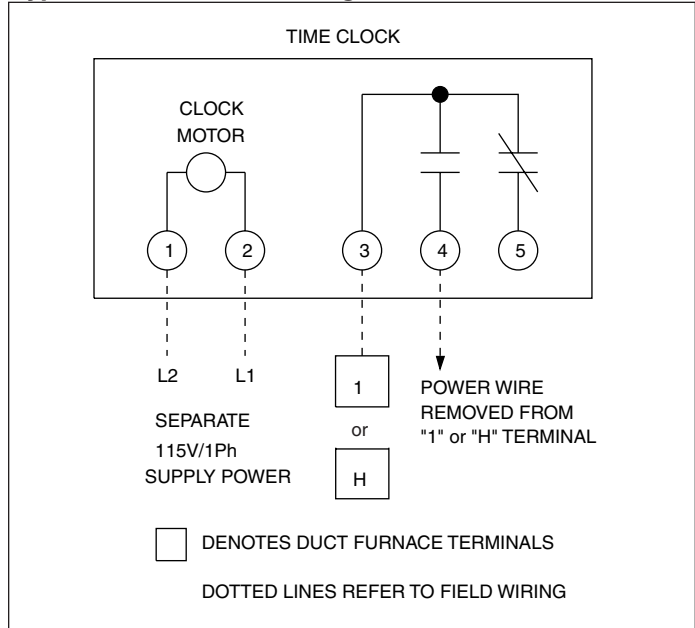

## Programming

The EC7000 controller is a user-friendly controller designed for ease of programming. Please see component supplier literature included with the controller for specific instructions on setup and programming of the controller.

Figure 2.2

### Dimensions of EC7000 (All dimensions in inches)

