

SUBMITTAL DATA

TRIMFIN™ commercial fin tube radiation

Model SP-14

Job name & location _____

Architect _____ Engineer _____

Contractor _____ Order No. _____

Submitted by _____

Date _____

Sheet _____ of _____

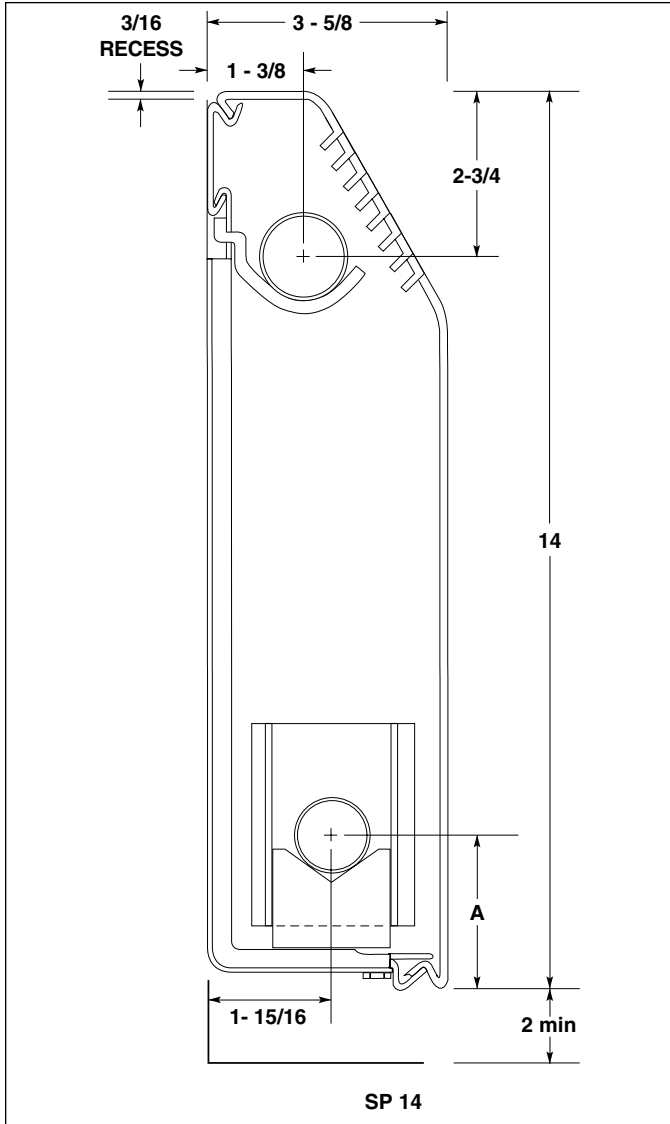

Enclosure Specifications

LENGTHS: 2' to 8' in 6" increments.
 FRONT: 18 ga. , 16 ga. or 14 ga. steel.
 DAMPER: (optional) Knob Operator , Tamper Proof .
 FINISH: light tan baked on prime coat enamel (standard) .
 OPTIONAL BAKED ENAMEL COLORS:

- Per AIR75-402 _____
- Per AIR75-400 _____
- Hanger strip: 20 ga. aluminized steel (standard)
- Hanger Strip with Full Back Panel: (optional) 20 guage steel
- Bottom Inlet Panel: (optional) 20 guage steel

Enclosure and Element Supports

- Enclosure Wall Support w/o Cradle-EWS-14
- Enclosure Wall Support with Cradle for Fin size 3-1/4 x 2-3/4 – EWS-1410
- Enclosure Wall Support with Cradle for Fin size 4-1/4 x 2-3/4 – EWS-1420
- Element Support Assembly for Fin size 3-1/4 x 2-3/4 – ESA-10
- Element Support Assembly for Fin size 4-1/4 x 2-3/4 – ESA-20
- Return Pipe Hanger

SEAMLESS COPPER TUBE DIAMETER:

3/4" 1" 1-1/4"

FIN SIZE: 3-1/4" x 2-3/4" 0.018" aluminum (one or two rows)
 4-1/4" x 2-3/4" 0.018" aluminum (one row only)

FINS PER FOOT:

34 42 50

AVERAGE WATER TEMPERATURE _____ °F

WATER FLOW RATE: _____ GPM, _____ FT/SEC

ENTERING AIR TEMPERATURE _____ °F

NUMBER OF ROWS OF ELEMENT: ONE TWO

RATING: _____ BTU/HR/FT

ENCLOSURE DIMENSIONS			
		A	
TUBE SIZE	FIN SIZE	MOUNTED TO EWS	MOUNTED TO ESA
3/4"	3-1/4" X 2-3/4"	2-7/16"	2-3/4" – 3-3/4"
	4-1/4" X 2-3/4"	2-15/16"	3-5/16" – 4-5/16"
1"	3-1/4" X 2-3/4"	2-9/16"	2-15/16" – 3-15/16"
	4-1/4" X 2-3/4"	3-1/8"	3-1/2" – 4-1/2"
1-1/4"	3-1/4" X 2-3/4"	2-11/16"	3-1/16" – 4-1/16"
	4-1/4" X 2-3/4"	3-1/4"	3-5/8" – 4-5/8"

AIR12-403.1

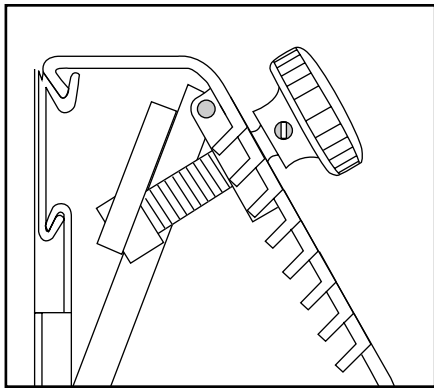

**KNOB
DAMPER**

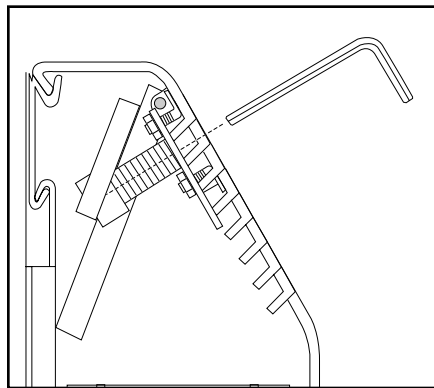

**TAMPERPROOF
DAMPER**

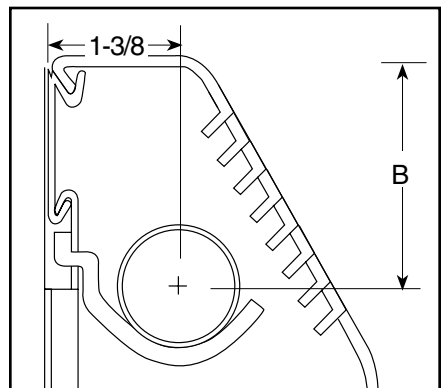

**RETURN PIPE
HANGER**

NOTE: Dampers and return pipe hanger cannot be used together.

TUBE SIZE	B
3/4"	2-15/16" – 3-11/16"
1"	2-13/16" – 3-9/16"
1-1/4"	2-11/16" – 3-7/16"

Accessories

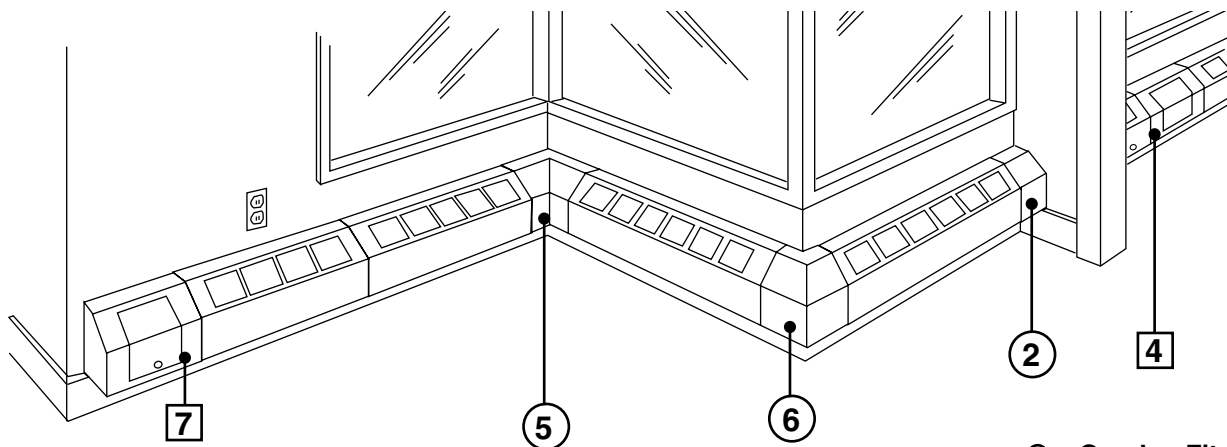

TYPICAL ENCLOSURE LAYOUT

○ = Overlap Fit
□ = Slip Joint

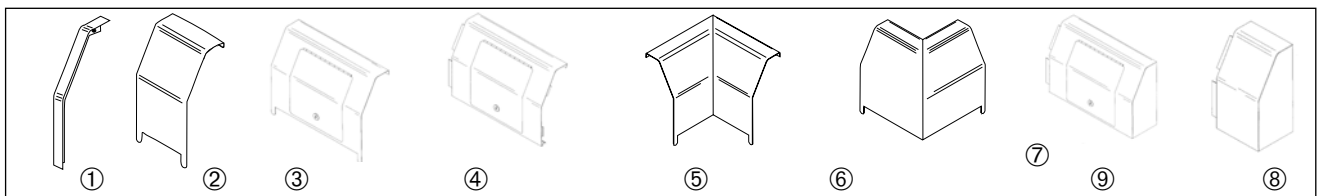

Ref. No.	Accessory Description
1	Extension Wall Support (R or L)
2	5" Extension (Overlap)
3	12" Extension w/ Door (Overlap)
4	12" Access Enclosure (Slip Joint)
5	90° Inside Corner (Overlap)
6	90° Outside Corner (Overlap)
8	3" End Cap (Slip Joint) (R or L)
7	12" End Cap w/Door (Slip Joint) (R or L)
9	12" End Cap (Slip Joint) (R or L)