

SUBMITTAL DATA commercial fin tube radiation

Model F Front Outlet

Job name & location _____ Date _____
 Architect _____ Engineer _____ Sheet _____ of _____
 Contractor _____ Order No. _____
 Submitted by _____

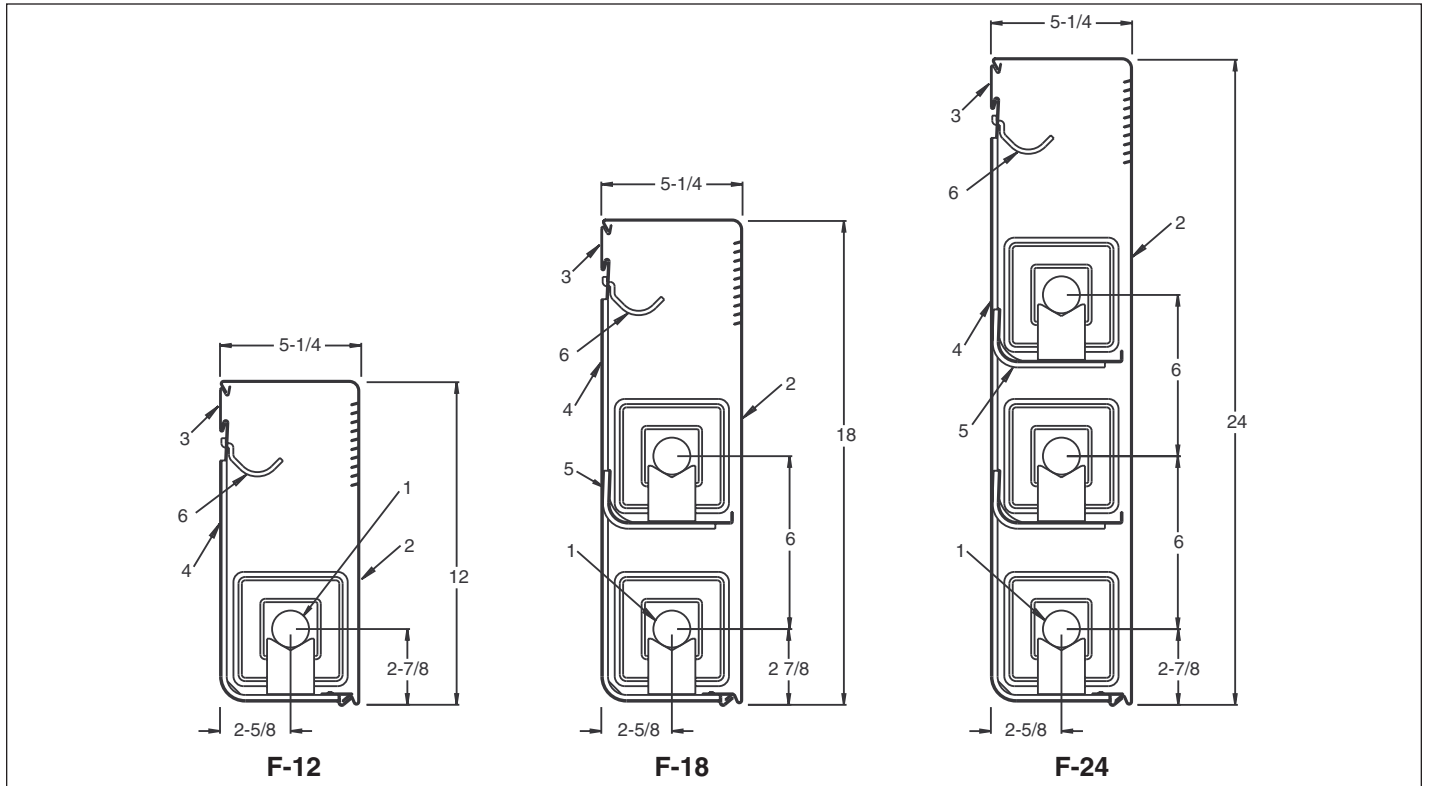

- 1 - Heating Element
- 2 - Enclosure
- 3 - Hanger Strip
- 4 - Enclosure Wall Support (EWS)
- 5 - Element Support Assembly (ESA)
- 6 - Return Pipe Hanger

Enclosure Specifications

Lengths: 2' to 8' in 6" increments
 Model: F-12 F-18 F-24
 Gauge: 18 ga. 16 ga. 14 ga.
 Standard Baked Enamel Finish: TR-13 Tan
 Optional Baked Enamel Finish:
 Per AIR75-402 _____
 Per AIR75-400 _____
 Dampers: Knob Operated Tamper Proof

Heating Element Specifications

Seamless copper tube diameter:
 3/4" 1" 1-1/4"
 Aluminum fin size:
 4-1/4" x 4-1/4" 2-3/4" x 4-1/4"
 Aluminum fins/ft:
 34 42 50
 Rows of Elements:
 1 2 @ 12"
 2 @ 6" 3 @ 6"

Performance

Average water temperature _____ °F
 Water flow rate: _____ GPM, _____ Ft/sec.
 Steam Pressure: _____ psi
 Entering Air Temperature: _____ °F
 Rating: _____ Btu/hr/ft

AIR12-422.1

Model F Front Outlet Enclosure Supports

Enclosure wall supports (EWS):

- 12" enclosure EWS-12
- 18" enclosure EWS-18
- 24" enclosure EWS-24

Enclosure wall support (EWS) with one element cradle attached:

- | | | |
|---------------|-----------------------------------|-----------------------------------|
| | 3/4" & 1" tube | 1-1/4" tube |
| 12" enclosure | <input type="checkbox"/> EWS-1275 | <input type="checkbox"/> EWS-1212 |
| 18" enclosure | <input type="checkbox"/> EWS-1875 | <input type="checkbox"/> EWS-1812 |
| 24" enclosure | <input type="checkbox"/> EWS-2475 | <input type="checkbox"/> EWS-2412 |

Element support assembly (ESA):

- 3/4" & 1" tube ESA-75
- 1-1/4" tube ESA-12

Accessories - 20 gauge

- | | | | |
|---|--|--|---|
| <input type="checkbox"/> 12" enclosure | <input type="checkbox"/> 18" enclosure | <input type="checkbox"/> 24" enclosure | <input type="checkbox"/> 18" Wide valve compartment (S) |
| <input type="checkbox"/> Wall support - left | | | <input type="checkbox"/> 12" Wide end enclosure - left (S) |
| <input type="checkbox"/> Wall support - right | | | <input type="checkbox"/> 12" Wide end enclosure - right (S) |
| <input type="checkbox"/> 5" Wide enclosure extension (O) | | | <input type="checkbox"/> 12" Wide end enclosure w/access door - left (S) |
| <input type="checkbox"/> 12" Wide enclosure extension (O) | | | <input type="checkbox"/> 12" Wide end enclosure w/access door - right (S) |
| <input type="checkbox"/> 12" Wide enclosure extension w/access door (O) | | | <input type="checkbox"/> End cap - left (S) |
| <input type="checkbox"/> 90° Inside corner (O) | | | <input type="checkbox"/> End cap - right (S) |
| <input type="checkbox"/> 90° Outside corner (O) | | | |
| <input type="checkbox"/> 12" Wide valve compartment (S) | | | |

(O) overlapping fit (S) slip joint fit to enclosure

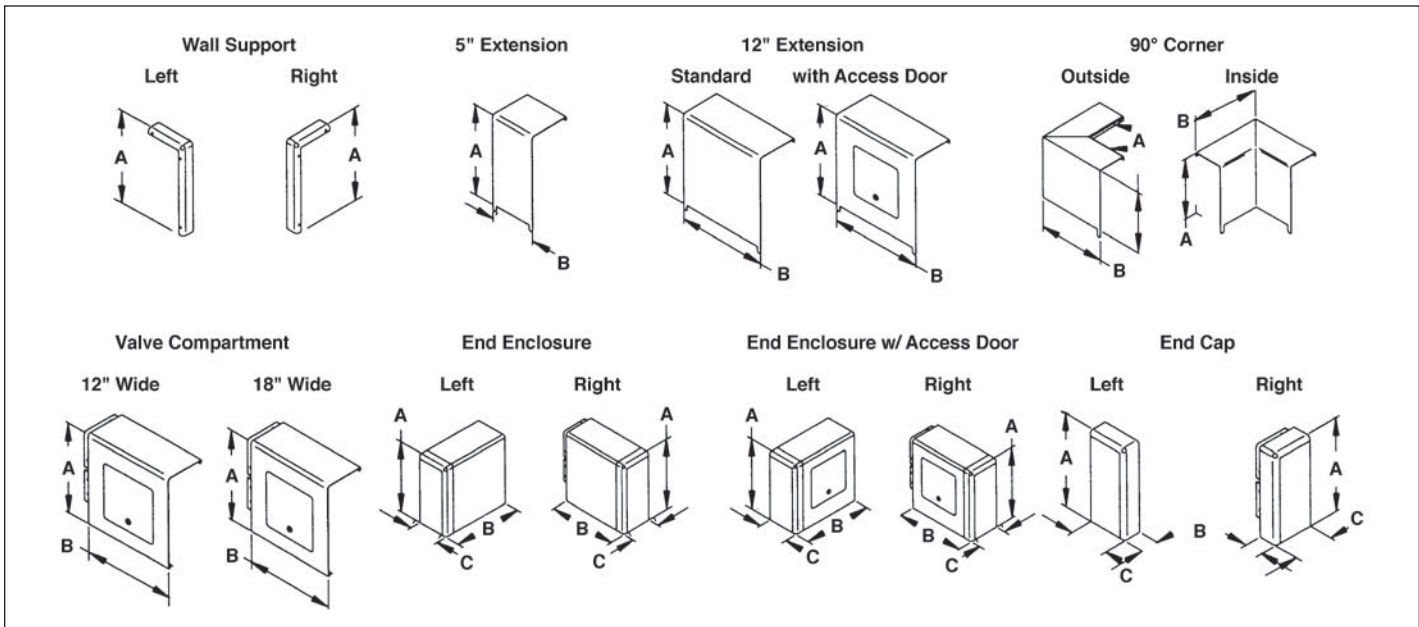

Accessory Dimensions

Enclosure				12" Extension		90° Corner		Valve Compartment		End Enclosure		End Cap
	Dim	Wall Support	Extension	Standard	w/Access Door	Inside	outside	12" Wide	18" Wide	Standard	w/Access Door	
F-12/18/24	A	12/18/24	12/18/24	12/18/24	12/18/24	12/18/24	12/18/24	12/18/24	12/18/24	12/18/24	12/18/24	12/18/24
	B		5	12	12	8.25	9	12	18	12	12	1.50
	C					4.25				5.25	5.25	5.25